

Statistics on investment funds (InvV)

Electronic Reporting System

XML format description

Last updated: 13 January 2025

Contents

1	Introduction	4
1.1	Changes as of the reporting month December 2025	4
1.2	Document history	4
2	Submission method	5
2.1	Bundesbank NExt	5
3	Report file	6
3.1	File name	6
3.1.1	Bundesbank NExt	6
3.2	File format	6
3.2.1	Notation	6
3.2.2	Character set	6
3.2.3	Name spaces	6
3.3	Element descriptions	7
3.4	Data types	8
3.4.1	Elements	8
3.4.2	Simple data types	9
3.4.3	Complex data types	12
3.4.4	Groups	19
4	InvV report	20
4.1	Structure of the XML report	20
4.2	LIEFERUNG-INVV2	21
4.2.1	Attributes	21
4.2.2	Elements	21
4.2.3	Structure	22
4.2.4	Example	23
4.3	MELDUNG	24
4.3.1	Attributes	24
4.3.2	Elements	24
4.3.3	Structure	25
4.3.4	Example	25
4.4	InvV forms	26
4.4.1	ALLGEMEIN_INVV (V10390)	26
4.4.2	MONATLICH_INVV (V10391)	35
5	Annex	44
5.1	Code table organisationsform	44
5.2	Code table typ	44
5.3	Code table art_inhaber_offen	45
5.4	Code table art_mittel	45
5.5	Code table art_ertrag	46
5.6	Code table notierung	46
5.7	Code table ruecknahmearart	47
5.8	Code table index_abbildung	47
5.9	Code table nutzungsart	47
5.10	Code table wpArt	48
5.11	Code table fristigkeit	48
5.12	Code table sektor	49
5.13	Code table geogr_fokus	49
5.14	Code table renten_fokus	50
5.15	Code table immo_fokus	50
5.16	Code table esg_typ	50
5.17	Code table verm_pos	51
5.18	Code table krypto	51

If you have any questions, please do not hesitate to contact us at the following email address:

if-statistik@bundesbank.de

1 Introduction

Using the XML-based electronic reporting system (*XML-basierten elektronischen Meldewesen* – XMW), reports can be submitted to the Deutsche Bundesbank in XML format.

This document describes the XML format used to submit reports for the statistics on investment funds to the Deutsche Bundesbank.

Technical documentation (XML schema files) and the examples shown in this document are available on the Deutsche Bundesbank’s website at:

<https://www.bundesbank.de/en> > Service > Reporting systems > Banking statistics > Investment funds statistics

Knowledge of XML is required to understand this document. For information about XML, see: <https://www.w3.org/XML/>

1.1 Changes as of the reporting month December 2025

The new ECB Regulation (EU) 2024/1988 introduces some changes to the existing XML reporting template from 2015. Here is a brief overview of the key changes:

- In the new template, the root element is named <LIEFERUNG-INVV2>.
- Forms 10389 and 10392 are no longer required, meaning that the reporting elements <ALLGEMEIN_GESSELLSCHAFT> and <BEREINIGUNGEN> are also no longer required.
- All euro amounts are to be stated in full euro (no longer in thousands of euro).
- In future, for the purposes of calculating adjustments, unique identifiers (“OBJEKTID”) must be used for some reporting items. These identifiers must be unique across all reporting months and must always be assigned to the same asset and liabilities position.
- To avoid duplicating information within an XML report file, unique keys have been assigned to identifiers.
- A period is used as the decimal separator, instead of a comma as was previously the case.

1.2 Document history

No	Date	Change(s)
1	18.10.2024	Document created
2	13.01.2025	claims extended by LEVERAGED_LOAN cryptocurrency values extended by STUECKZAHL

2 Submission method

The monthly report for the statistics on investment funds (*Statistik über Investmentvermögen* – InvV) must be submitted as an XML file via Bundesbank NExt.

2.1 Bundesbank NExt

Bundesbank NExt is the replacement for the Bundesbank's ExtraNet.

For information about NExt and registration options, see:

<https://www.bundesbank.de/en> > Service > NExt

3 Report file

3.1 File name

3.1.1 Bundesbank NExt

Bundesbank NExt is the replacement for the Bundesbank's ExtraNet.

For information about NExt and file naming conventions, see:

<https://www.bundesbank.de/en> > Service > NExt

3.2 File format

Report files must be submitted in XML format.

To assist in creating the file, XML documentation and example files are available for download from the Bundesbank's website.

To ensure data integrity, we recommend validating the generated XML files using the schema definitions:

Name	Description	
BbkXmwBasis.xsd	Basic schema for XML reports to the Bundesbank	Basic schema
BbkXmwInvv_2026.xsd	Schema for XML reports on investment funds statistics	InvV schema

3.2.1 Notation

XML is case-sensitive. In the Bundesbank's XML reporting system, the names of elements are usually written in upper case letters and those of attributes in lower case letters. If different elements are located at the same hierarchical level, the sequence of elements is generally the determining factor. The sequence of attributes is arbitrary.

3.2.2 Character set

The character encoding standard used is UTF-8 (recommended) or Latin-1/West European (ISO-8859-1). For free text fields, adherence to the DIN 91379 standard is mandatory, which is ensured by the XML schema.

3.2.3 Name spaces

To differentiate the Bundesbank's basic XMW schema (BbkXmwBasis.xsd) from the specific InvV schema (BbkXmwInvv_2026.xsd), the following namespaces are used:

File name	Designation	Namespace
-----------	-------------	-----------

BbkXmwBasis.xsd	Basic schema	http://www.bundesbank.de/xmw/2003-01-01
BbkXmwInvv_2026.xsd	InvV schema	http://www.bundesbank.de/statistik/invv/v2

In the examples, the InvV namespace is used as the standard namespace, i.e. the elements of this namespace do not require any qualification. For the general XMW namespace from the basic schema, the abbreviation “bbk” is used, i.e. all elements from this namespace must be qualified with “bbk”.

3.3 Element descriptions

Elements are described using the following table format:

Name	Req. (= required)	Value range/format	Comments
ELEMENT NAME	+ Element is required - Element can be omitted*	Entry or description of permissible element content	Comment about the element
attribute	+ Attribute is required - Attribute can be omitted	Entry or description of permissible attribute content	Comment about the attribute

* If an element is to be omitted, then the element must be omitted in its entirety, not only its contents

3.4 Data types

The XMW schema definitions use self-defined elements and data types. These are described below.

3.4.1 Elements

InvV schema

BBK_INSTITUTS_ID

Bundesbank institution identification number:

The institution identification number is assigned to the reporting company by the Bundesbank. It is a five-digit number.

The Bundesbank also assigns the required institution ID to third parties that are contracted by a company to submit the reports.

INTERNAL_WP_KNR

Internal securities identification number:

The internal securities identification number is used to designate holdings of securities that do not have an ISIN, for which information should be provided in item 11 of the reporting form V10391.

The internal securities identification number is made up of 12 alphanumeric characters: upper case letters and/or numbers.

General schema

No elements from the general schema are used.

3.4.2 Simple data types

InvV schema

Technical, simple data types

Within the UTF-8 encoding approved for InvV in the XMW, encoding is restricted to the DIN 91379 standard. The following technical data types are defined for this purpose:

datatypeA

DIN 91379 data type A:

Data type A indicates which characters should be used for the names of natural persons.

datatypeA_1_80

DIN 91379 data type A with 1-80 characters

datatypeB

DIN 91379 data type B:

Data type B is used primarily for other names, such as town/city names and street names with house numbers.

datatypeB_1_80

DIN-91379 data type B with 1-80 characters

datatypeD

DIN 91379 data type D:

This data type can only be supported by IT procedures that also support the non-normative characters in the DIN 91379 standard. Data type D was designed primarily for names of legal entities and names of products.

datatypeD_1_150

DIN 91379 data type D with 1-150 characters

datatypeE

This data type can only be supported by IT procedures that also support the non-normative characters in the DIN 91379 standard. Data type E was designed for all normative and extended characters of the DIN 91379 standard. This data type can be used for cross-border data exchange if Greek and Cyrillic characters are also required. It therefore represents the technical implementation of the interface agreement “All normative and non-normative characters according to the DIN 91379 standard” (“*Alle nach Norm DIN 91379 normativen und nicht-normativen Schriftzeichen*”). Texts with letters or non-letters that are not included in the DIN 91379 standard, such as Asian or Arabic characters, are not permitted.

datatypeE_1_40

DIN 91379 data type E with 1-40 characters

General, simple data types

text0

Blank entry

upperAlphanum

Latin upper case letters and numbers

upperAlphanum_1_30

Latin upper case letters and numbers (1-30 characters)

integer15

15-digit positive or negative integer

integer15pos

15-digit positive integer

doubleStrictNeg

Strictly negative double-precision floating-point number

doublePos

Positive double-precision floating-point number

nichtZutreffend

“Not applicable” entry if an item does not apply

jjjjmmtt

Date entry in the format YYYY-MM-DD

jjjjmmtt_nichtzutreffend

Date entry in the format YYYY-MM-DD or “nicht zutreffend” (“Not applicable”)

unbekannt

“Unknown” entry

isoLand

Country code format according to ISO 3166:

Two upper case letters (e.g. “DE” for Germany) or a number and an upper case letter or an upper case letter and a number (one number and one upper case letter are permitted for international organisations, e.g. “1Z” for the United Nations)

isoWaehrung

Currency code format according to ISO 4217:

Three upper case letters (e.g. “EUR” for euro)

isinInternational Securities Identification Number (ISIN):

Two Latin upper case letters, followed by nine upper case letters or numbers, followed by a number

interne_knrInternal identification number:

The internal identification number of investment funds without an ISIN for which a report is to be submitted consists of five digits.

In the case of closed-end investment funds, the internal ID number corresponds to the BBK_INSTITUTS_ID.

bafin_id

Federal Financial Supervisory Authority (BaFin) ID of the company (eight numeric characters) or “unbekannt” (“Unknown”)

leiLegal Entity Identifier:

The legal entity identifier (LEI) is based on ISO standard 17442 and consists of 20 alphanumeric characters. If the LEI is unknown, “unbekannt” (“Unknown”) can be entered.

emailValid email address:

A valid email address in the format “characterstring@characterstring.do” (do = two to four-digit domain name). A personal or functional email address can be entered.

telnrValid telephone number format:

A valid telephone number consists of a sequence of digits. The prefix can optionally be marked with “+” followed by 3 to 39 digits.

General schema

bbk:jaNein

“ja” (“yes”) or “nein” (“no”):

The entry “ja” (“yes”) or “nein” (“no”) must always be written in lower case.

3.4.3 Complex data types

General schema

bbk:adresse

The data type `bbk:adresse` standardises the general format of companies’ address data. It is used in the elements `<bbk:ERSTELLER>` (creator), `<bbk:ADRESSAT>` (addressee), `<bbk:ABSENDER>` (sender), and `<bbk:MELDER>` (reporter) and contains the following sub-elements:

Name	Req	Value range/format	Comments
	.		
BBK_INSTITUTS_ID	+	Alphanumeric, 5 characters	Identification number of company that submits the XML report
NAME	+	Up to 80 alphanumeric characters; may not be empty	Name of company
STRASSEor POSTFACH	-	Up to 80 alphanumeric characters; may not be empty	Address of company
PLZ	-	Alphanumeric, 1 to 20 characters	Postal code
ORT	-	Up to 80 alphanumeric characters; may not be empty	Town/city
LAND	-	2 upper case letters	Country of domicile of company
KONTAKT	+	See below	Contact person or unit

KONTAKT

Name	Req	Value range/format	Comments
	.		
ANREDE	-	Up to 80 alphanumeric characters; may not be empty	Form of address
VORNAME	-	Up to 80 alphanumeric characters; may not be empty	First name of contact person
ZUNAME	+	Up to 80 alphanumeric characters; may not be empty	Last name of contact person or name of functional contact unit
ABTEILUNG	-	Up to 80 alphanumeric characters; may not be empty	Department
TELEFON	+	Valid telephone number	Telephone number (with extension)
FAX	-	Valid telephone number	Fax number
EMAIL	-	Valid email address	Email address

EXTRANET-ID	-	“EXN” followed by 5 letters or digits	User name in the Bundesbank’s ExtraNet (if available)
-------------	---	---------------------------------------	---

Example: <bbk:ABSENDER>

```

<bbk:ABSENDER>
  <BBK_INSTITUTS_ID>00123</BBK_INSTITUTS_ID>
  <bbk:NAME>Beispiel-Gesellschaft</bbk:NAME>
  <bbk:STRASSE>ABC-Straße 1</bbk:STRASSE>
  <bbk:PLZ>12345</bbk:PLZ>
  <bbk:ORT>Beispiel-Ort</bbk:ORT>
  <bbk:LAND>DE</bbk:LAND>
  <bbk:KONTAKT>
    <bbk:ANREDE>Herr</bbk:ANREDE>
    <bbk:VORNAME>Hans</bbk:VORNAME>
    <bbk:ZUNAME>Schmidt</bbk:ZUNAME>
    <bbk:ABTEILUNG>Investmentvermoege</bbk:ABTEILUNG>
    <bbk:TELEFON>000/111-999</bbk:TELEFON>
    <bbk:FAX>000/111-888</bbk:FAX>
    <bbk:EMAIL>hans.schmidt@gesellschaft.de</bbk:EMAIL>
    <bbk:EXTRANET-ID>EXNTESTA</bbk:EXTRANET-ID>
  </bbk:KONTAKT>
</bbk:ABSENDER>

```

InvV schema (V10390)

adresse

General address type for the InvV report, consisting of an identifier and additional information:

Name	Req	Value range/format	Comments
	.		
BBK_INSTITUTS_ID	+	BBK_INSTITUTS_ID	Bundesbank institution identification number of company
NAME	+	datatypeD_1_150	Name of company
STRASSEor POSTFACH	+	datatypeB_1_80	Address of company
PLZ	+	upperAlphanum, 1-20 characters	
ORT	+	datatypeB_1_80	
Country	+	isoLand	
KONTAKTE	+	(can be repeated as often as required)	Contact persons within company (form of address, first name, last name, telephone, email)
ANREDE	+	datatypeA_1_80	
VORNAME	-	datatypeA_1_80	
NACHNAME	+	datatypeA_1_80	
TELEFON	+	telnr	
EMAIL	+	email	

gesellschaftsinNameLand

Company information: ISIN, name, country:

Name	Req	Value range/format	Comments
	.		
(InvV identifier)	+	invv_kennung	Identifier of investment fund (ISIN or internal identifier)
NAME	+	datatypeD_1_150	Name of company
LAND	+	isoLand	Country of domicile of company

gesellschaftNameLand

Company information: Name, country:

Name	Req	Value range/format	Comments
	.		
NAME	+	datatypeD_1_150	Name of company
LAND	+	isoLand	Country of domicile of company

InvV schema (V10391)
wpMitISIN

Information on the item “WERTPAPIERE_MIT_ISIN” from V10391 (can be repeated as often as required):

Name	Req	Value range/format	Comments
	.		
ISIN	+	isin	ISIN of security
(Price/unit data)	+	wpKursStueck	Price or number of units and currency of security
DARUNTER_WP_LEIHG	+	doublePos	Of which: Securities lending operations (nominal value in euro or number of units)
DARUNTER_ECHTE_PG	+	doublePos	Of which: Securities sold under repurchase agreements where there is a firm commitment to reverse the operation (nominal value in euro or number of units)

wpOhneISIN

Information on the item “WERTPAPIERE_OHNE_ISIN” from V10391 (can be repeated as often as required):

Name	Req	Value range/format	Comments
	.		
INTERNE_KNR	+	INTERNE_WP_KNR	Internal identifier of security
WERTPAPIERART	+	Code table wpArt	Type of security
EMITTENTENCODE	+	upperAlphanum_1_30	Identifier of issuer
EMITTENTENNAME	+	datatypeD_1_150	Name of issuer
EMITTENTENLAND	+	isoLand	Country of issuer
EMITTENTENSEKTOR	+	Code table sektor	Sector of issuer
EMISSIONSDATUM	+	jjjjmmtt	Date of issue (YYYY-MM-DD)
FAELLIGKEIT	+	jjjjmmtt_nichtzutreffend	If available, date of maturity (YYYY-MM-DD), otherwise “nicht zutreffend” (“Not applicable”) (for perpetual securities)
ZINS	+	doublePos	Coupon rate of security
(Price/unit data)	+	wpKursStueck	Price or number of units and currency of security
DARUNTER_WP_LEIHG	+	doublePos	Of which: Securities lending operations (nominal value in euro or number of units)

DARUNTER_ECHTE_PG	+	doublePos	Of which: Securities sold under repurchase agreements where there is a firm commitment to reverse the operation (nominal value in euro or number of units)
-------------------	---	-----------	--

bankguthaben

Information on the item “BANKGUTHABEN” from V10391 (can be repeated as often as required):

Name	Req	Value range/format	Comments
	.		
BETRAG	+	integer15	Amount in euro
WAEHRUNG	+	isoWaehrung	Currency
LAND	+	isoLand	Country of domicile of institution
SEKTOR	+	Code table sektor	Sector of institution
FRISTIGKEIT	+	Code table fristigkeit	Maturity of bank deposit

kryptowerte

Information on the item “KRYPTOWERTE” from V10391 (can be repeated as often as required):

Name	Req	Value range/format	Comments
	.		
BETRAG	+	integer15	Amount in euro
KRYPTOWERT	+	Code table krypto	Crypto-asset
STUECKZAHL	+	doublePos	Number of cryptocurrency units

forderungen

Information on the items “DARL_IMMO_GES”, “SCHULDSCHEINDARLEHEN”, “UNVERBR_DARL_FORD”, “FORD_WP_LEIH:GESCH” and “SONST_FORDERUNGEN” from V10391 (can be repeated as often as required):

Name	Req.	Value range/format	Comments
BETRAG	+	integer15pos	Amount in euro
WAEHRUNG	+	isoWaehrung	Currency
LAND	+	isoLand	Country of domicile of debtor
SEKTOR	+	Code table sektor	Sector of debtor
FRISTIGKEIT	+	Code table fristigkeit	Maturity of claim
VERBUNDENES_UNTERNEHMEN	+	bbk:jaNein	Indicator of whether debtor is an affiliated company

LEVERAGED_LOAN	+	bbk:jaNein	Indication of whether the claim against the debtor is a leveraged loan
----------------	---	------------	--

nf_vermoegen

Information on the items “GRUNDSTUECKE_UNBEBAUT”, “SCHIFFE”, “CONTAINER”, “LUFTFAHRZEUGE”, “ENERGIE_ANLAGEN” and “SONSTIGE_NF_VERM” from V10391 (can be repeated as often as required):

Name	Req	Value range/format	Comments
	.		
BETRAG	+	integer15pos	Amount in euro
LAND	+	isoLand	Country in which asset is located or country of manufacture for movable assets
OBJEKTID	+	upperAlphanumeric_1_30	Internal object ID of asset

nf_vermoegen_grundst_beb

Information on the item “GRUNDSTUECKE_BEBAUT” from V10391 (can be repeated as often as required):

Name	Req	Value range/format	Comments
	.		
BETRAG	+	integer15pos	Amount in euro
LAND	+	isoLand	Country in which developed land is located
NUTZUNGSART	+	Code table nutzungsart	Type of use of developed land
OBJEKTID	+	upperAlphanumeric_1_30	Internal object ID of asset

beteiligungen

Information on the items “BETEILIGUNG_IMMOGESELLSCHAFT”, “BETEILIGUNG_OEPP” and “BETEILIGUNG_SONST” from V10391 (can be repeated as often as required):

Name	Req	Value range/format	Comments
	.		
BETRAG	+	integer15pos	Amount in euro
LAND	+	isoLand	Country of domicile of company
OBJEKTID	+	upperAlphanumeric_1_30	Internal object ID of asset

derivate

Information on the items “DERIVATE_AKTIVA” and “DERIVATE_PASSIVA” from V10391 (can be repeated as often as required):

Name	Req	Value range/format	Comments
	.		

BETRAG	+	integer15pos	Amount in euro
TRANSAKTIONEN_ VOLUMEN	+	integer15	Transactions in financial derivatives in euro
LAND	+	isoLand	Country of counterparties

sonst_vermoegen

Information on the item “SONSTIGES_VERMOEGEN” from V10391:

Name	Req	Value range/format	Comments
	.		
GESAMTBETRAG	+	integer15pos	Total amount in euro (item 70)
ZINSEN_EINLAGEN	-	integer15pos	Of which: Accrued interest on deposits (in thousand euro) (item 71)
ZINSEN_WERTPAPIER E	-	integer15pos	Of which: Accrued interest on debt securities (in thousand euro) (item 72)
FORDERUNGEN	-	integer15pos	Of which: Claims from dividends (in thousand euro) (item 73)

verbindlichkeiten

Information on the items “KREDITE” and “VERB_WP_LEIH_GESCH” from V10391 (can be repeated as often as required):

Name	Req	Value range/format	Comments
	.		
BETRAG	+	integer15pos	Amount in euro
WAEHRUNG	+	isoWaehrung	Currency
LAND	+	isoLand	Country of domicile of creditor
SEKTOR	+	Code table sektor	Sector of creditor
FRISTIGKEIT	+	Code table fristigkeit	Maturity of liability
MINDESTRESERVE PFL_INST	-	bbk:jaNein	Indicator of whether creditor is subject to minimum reserve requirements (only mandatory for money market funds)

sonst_verbindlichkeiten

Information on the item “SONSTIGE_VERBINDLICHKEITEN” from V10391:

Name	Req	Value range/format	Comments
	.		
GESAMTBETRAG	+	integer15pos	Total amount in euro (item 100)
ZINSEN_AUFGELAUFEN	-	integer15pos	Of which: Accrued interest (in euro) (item 101)

erl_vermpos

Information on the item “ERLOESE_VERMPOS” from V10391 (can be repeated as often as required):

Name	Req	Value range/format	Comments
	.		
BETRAG	+	integer15pos	Amount in euro
OBJEKTID	+	upperAlphanum_1_30	Internal object ID of asset
VERMOEGENSPOSITION	+	Code table verm_pos	Asset item of surrendered object

3.4.4 Groups

InvV schema

formular_kopf

Form header of the reports:

Name	Req	Value range/format	Comments
	.		
BBK_INSTITUTS_ID	+	BBK_INSTITUTS_ID	Bundesbank institution identification number
INVV_NAME	+	datatypeD_1_150	Name of investment fund
(InvV identifier)	+	invv_kennung	Identifier of investment fund (ISIN or internal identifier)

invv_kennung

Identifier of investment fund: ISIN. If no ISIN is available, an internal identifier must be provided:

Name	Req	Value range/format	Comments
	.		
ISIN or INTERNE_KNR	+	isin interne_knr	ISIN or internal identifier of investment fund

wpKursStueck

Price or number of units and currency of security

Name	Req	Value range/format	Comments
	.		
NOMINALWERT	+	doublePos	Securities quoted as a percentage: Nominal value in euro and price as a percentage (at least 3 decimal places)
KURS	+	doublePos	

or

STUECKZAHL	+	doublePos	
------------	---	-----------	--

PREIS	+	doublePos	Securities quoted in number of units: Number of units and price per unit in euro (at least 2 decimal places)
WAEHRUNG	+	isoWaehrung	Currency

4 InvV report

4.1 Structure of the XML report

All XML files for reporting banking statistics have a common basic hierarchical structure. It begins with a root element containing address information (<LIEFERUNG-INVV2>). It contains a reporting element (<MELDUNG>), which, in turn, contains a form element. The form elements (<InvV-Formulare>) contain reporting data at the lowest hierarchical level.

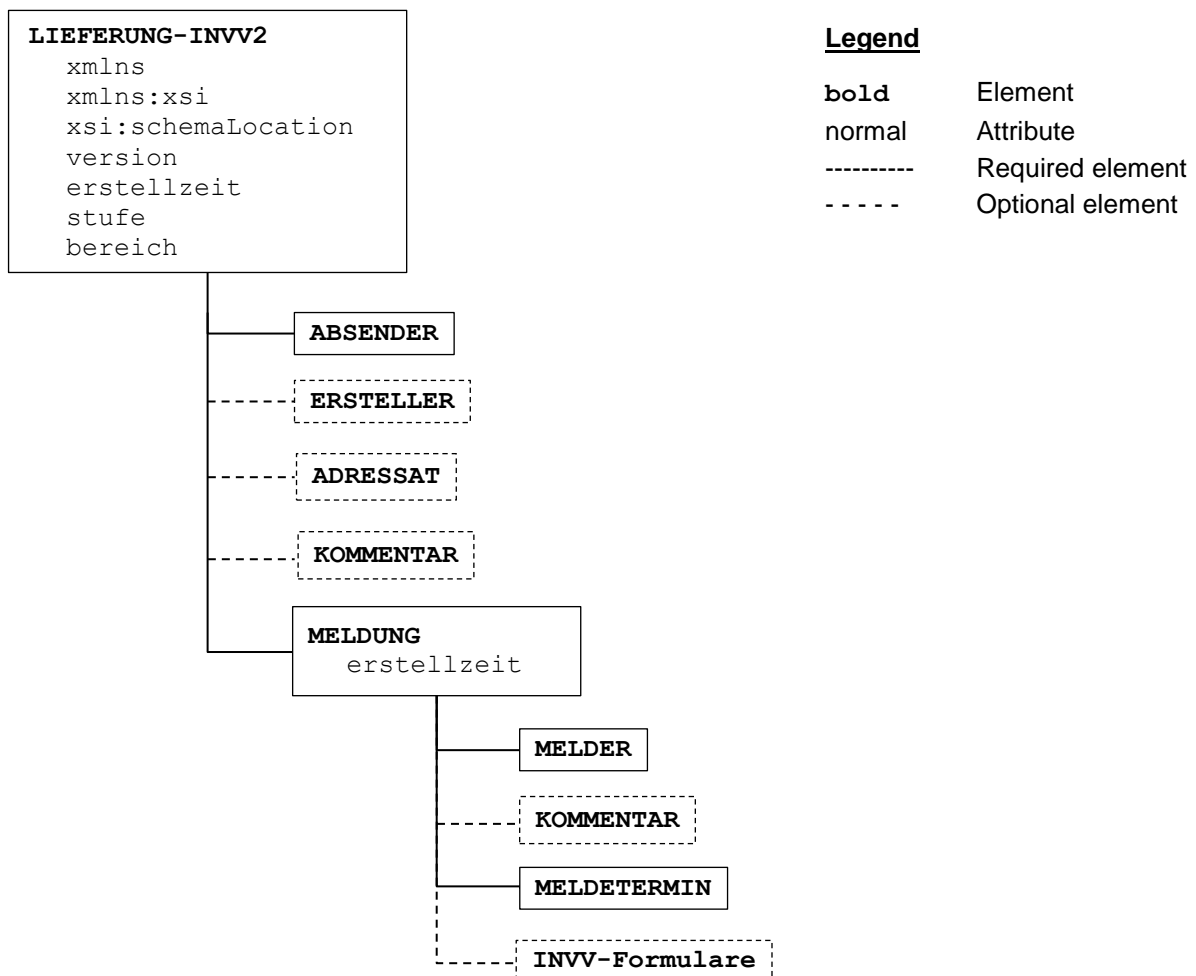

4.2 LIEFERUNG-INVV2

The root element of an InvV XMW report is the element <LIEFERUNG-INVV2>.

4.2.1 Attributes

Name	Req	Value range/format	Comments
	.		
xmlns	+	http://www.bundesbank.de/statistik/invv/v2	Namespace for XML reporting system for statistics on investment funds, version 2
xmlns:invv	-	http://www.bundesbank.de/statistik/invv/v2	Namespace for XML reporting system for statistics on investment funds, version 2
xmlns:bbk	+	http://www.bundesbank.de/xmw/2003-01-01	Namespace for XML reporting system
xmlns:xsi	+	http://www.w3.org/2001/XMLSchema-instance	Namespace for XML schema definition
xsi:schemaLocation	+	http://www.bundesbank.de/statistik/invv/v2 BbkXmwInvv_2026.xsd	Search path for XML schema
version	+	"1.0"	Currently fixed
erstellzeit	+	yyyy-mm-ddThh:mm:ss	Example: 2026-01-03T12:00:00
stufe	+	"Test" or "Produktion"	Distinguishes between test and production data
dateireferenz	-	Whole number ("1", "2", etc.)	Counter for repeated submissions

4.2.2 Elements

Name	Req	Value range/format	Comments
	.		
bbk:ABSENDER	+	bbk:adresse	Address of sender
bbk:ERSTELLER	-	bbk:adresse	Address of creator
bbk:ADRESSAT	-	bbk:adresse	Address of addressee
bbk:KOMMENTAR	-		Comments on report
EINREICHER	+	adresse	Information on submitter (for technical feedback)
MELDUNG	+	See 4.3 MELDUNG	InvV report data

The element <bbk:ABSENDER> is of the data type `bbk:adresse`. Its contents include address information on the company that submitted the XML file. The first sub-element is <BBK_INSTITUTS_ID>, where the institution ID assigned by the Bundesbank to the reporting company should be entered.

The element <bbk:ERSTELLER> is optional and of the data type `bbk:adresse`. It contains address information on the creator of the XML report if this is not identical to the sender.

The element `<bbk:ADRESSAT>` is optional and of the data type `bbk:adresse`. As a general rule, it is not used for reports submitted to the Bundesbank. It is intended for use when exchanging data with third parties.

This address information is relevant for submission only, not for statistics on investment funds. The optional element `<bbk:KOMMENTAR>` is also not relevant for statistics on investment funds.

The element `<EINREICHER>` contains the submitter's contact details. Technical feedback on the content of the submitted report may be sent to this contact.

The element `<MELDUNG>` is a required element and may appear more than once. It contains the reporting forms for statistics on investment funds. A unique constraint ensures that there is only one message per reporting date in the XML file.

4.2.3 Structure

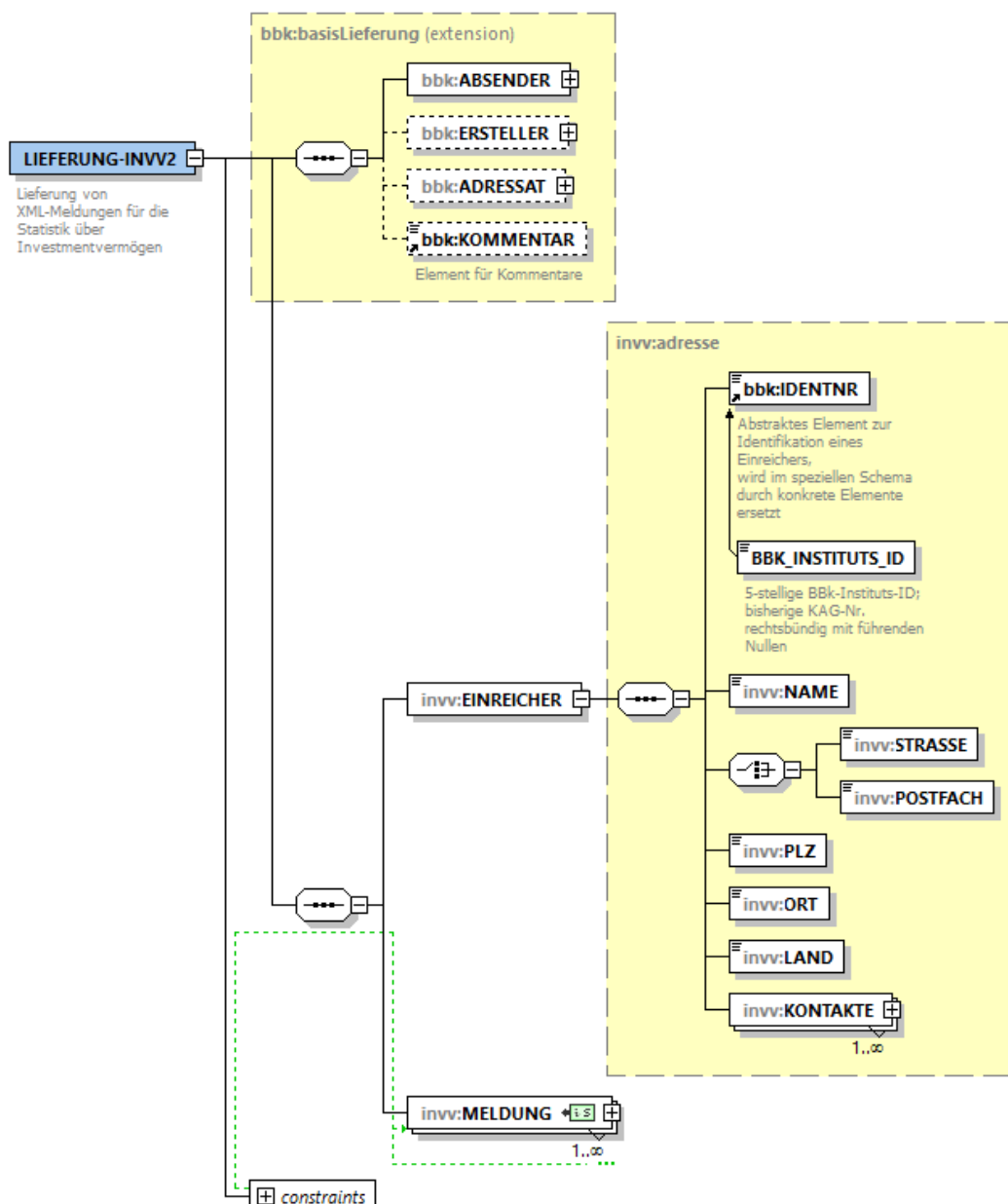

4.2.4 Example

```

<?xml version="1.0" encoding="UTF-8"?>
<LIEFERUNG-INVV2
  xmlns=http://www.bundesbank.de/statistik/invv/v2
  xmlns:invv=http://www.bundesbank.de/statistik/invv/v2
  xmlns:bbk=http://www.bundesbank.de/xmw/2003-01-01
  xmlns:xsi=http://www.w3.org/2001/XMLSchema-instance
  xsi:schemaLocation=http://www.bundesbank.de/statistik/invv/v2 BbkXmwInvv_2026.xsd
  version="1.0"
  erstellzeit="2026-01-03T12:00:00"
  dateireferenz="0"
  stufe="Test">
  <bbk:ABSENDER>
    <BBK_INSTITUTS_ID>00123</BBK_INSTITUTS_ID>
    <bbk:NAME>Beispiel-Gesellschaft</bbk:NAME>
  </bbk:ABSENDER>
  <bbk:ERSTELLER>
    <BBK_INSTITUTS_ID>00123</BBK_INSTITUTS_ID>
    <bbk:NAME>Beispiel-Gesellschaft</bbk:NAME>
  </bbk:ERSTELLER>
  <bbk:KOMMENTAR>Dies ist eine Testlieferung</bbk:KOMMENTAR>
  <EINREICHER>
    <BBK_INSTITUTS_ID>00123</BBK_INSTITUTS_ID>
    <NAME>Beispiel-Gesellschaft</NAME>
    <STRASSE>ABC-Straße 1</STRASSE>
    <PLZ>12345</PLZ>
    <ORT>Beispiel-Ort</ORT>
    <LAND>DE</LAND>
    <KONTAKTE>
      <ANREDE>Herr</ANREDE>
      <NACHNAME>Schmidt</NACHNAME>
      <TELEFON>+4969111999</TELEFON>
      <EMAIL>hans.schmidt@gesellschaft.de</EMAIL>
    </KONTAKTE>
  </EINREICHER>
  <MELDUNG erstellzeit="2026-01-03T12:00:00">
    <!-- ***** Meldung für die Statistik über Investmentvermögen ***** -->
  </MELDUNG>
</LIEFERUNG-INVV2>
    
```

4.3 MELDUNG

The reporting element of an InvV XMW report is the element <MELDUNG>.

4.3.1 Attributes

Name	Req. *	Value range/format	Comments
erstellzeit	+	yyyy-mm-ddThh:mm:ss	Example: 2026-01-03T12:00:00

4.3.2 Elements

Name	Req	Value range/format	Comments
	.		
bbk:MELDER	+	bbk:adresse	Master data of reporter
bbk:KOMMENTAR	-		Comments on report
bbk:MELDETERMIN	+	xs:gYearMonth	Reporting month (YYYY-MM)
ALLGEMEIN_INVV	-	4.4.1 ALLGEMEIN_INVV (V10390)	General information for the individual investment fund (V10390)
MONATLICH_INVV	-	4.4.2 MONATLICH_INVV (V10391)	Monthly report for investment funds (V10391)

There is no limit to the number of forms that may appear in the element <MELDUNG>, but there may only be one form per reporting date.

4.3.3 Structure

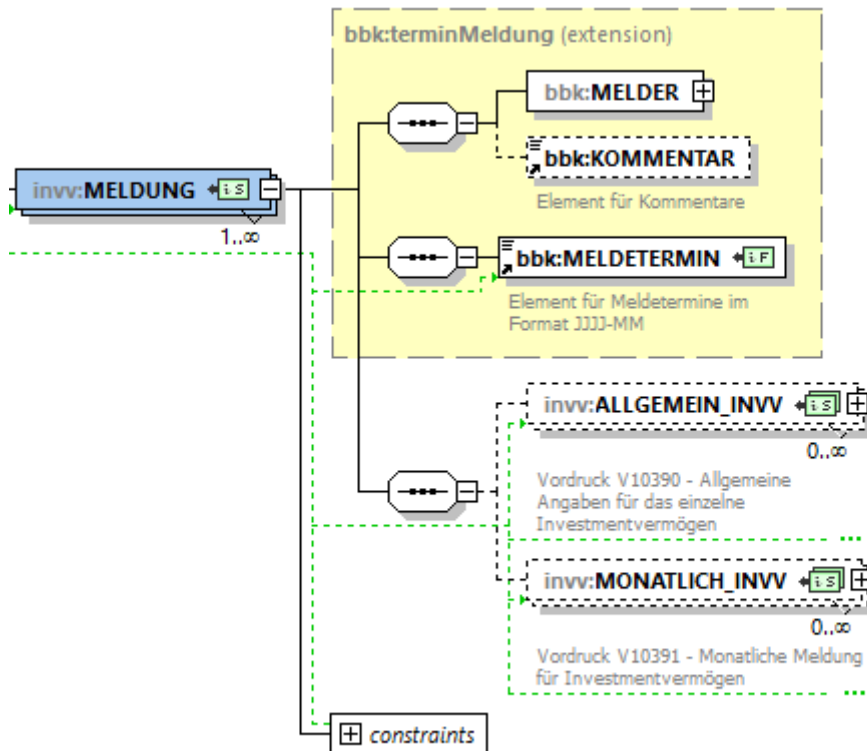

4.3.4 Example

```
<MELDUNG erstellzeit="2026-01-03T12:00:00">
  <!-- ***** Meldung für die Statistik über Investmentvermögen ***** -->
  <bbk:MELDER>
    <BBK_INSTITUTS_ID>00123</BBK_INSTITUTS_ID>
    <bbk:NAME>Beispiel-Gesellschaft</bbk:NAME>
    <bbk:STRASSE>ABC-Straße 1</bbk:STRASSE>
    <bbk:PLZ>12345</bbk:PLZ>
    <bbk:ORT>Beispiel-Ort</bbk:ORT>
    <bbk:KONTAKT>
      <bbk:ZUNAME>Otto</bbk:ZUNAME>
      <bbk:TELEFON>000/111-777</bbk:TELEFON>
    </bbk:KONTAKT>
  </bbk:MELDER>
  <bbk:KOMMENTAR>Dies ist eine Testmeldung</bbk:KOMMENTAR>
  <bbk:MELETERMIN>2025-12</bbk:MELETERMIN>
  <MONATLICH_INVV>
    <!-- InvV-Formular V10391 -->
  </MONATLICH_INVV>
</MELDUNG>
```

4.4 InvV forms

4.4.1 ALLGEMEIN_INVV (V10390)

This report is to be submitted without delay when an investment fund is launched, when unit categories or sub-funds are created, or when an investment fund is taken over, closed, transferred or merged.

For the first reporting month (December 2025), this report is to be submitted on a one-off basis for all existing investment funds.

If one or more characteristics change, the full report must be submitted again without delay.

Elements

Name	Req	Value range/format	Comments
	.		
(Form header)	+	formular_kopf	Bundesbank institution ID, name and identifier of investment fund
GESELLSCHAFT	+	See below: GESELLSCHAFT	Information on company
RECHT	+	isoLand	Applicable law (country): Country whose law governs the investment fund
BAFIN_ID	+	bafin_id	Federal Financial Supervisory Authority (BaFin) ID (8 numerical characters) of the investment fund or “unbekannt” (“Unknown”)
LEI	+	lei	Legal entity identifier (20 alphanumeric characters) of the investment fund or “unbekannt” (“Unknown”)

ERSTMELDUNG	+	See below: ERSTMELDUNG	Initial report
-------------	---	---------------------------	----------------

or

AENDERUNGSMELDUNG	+	See below: AENDERUNGSMELDUNG	Change report
-------------------	---	---------------------------------	---------------

or

LETZMELDUNG	+	See below: LETZMELDUNG	Final report
-------------	---	---------------------------	--------------

ORGANISATION	+	Code table organisationsform	Organisational form of investment fund (excluding “Sonstiges” (“Other”))
--------------	---	---------------------------------	--

or

ORGANISATION_GESCH L_SONSTIGE	+	datatypeE_1_40	Organisational form of closed-end investment fund: "Sonstiges" ("Other"); here: text entry
----------------------------------	---	----------------	--

TYP	+	Code table typ	Type of investment fund
-----	---	----------------	-------------------------

ART_INHABER_OFFEN	-	Code table art_inhaber_offen	Type of unit holder for open-end investment fund
-------------------	---	---------------------------------	--

or

ART_INHABER_GESCHL	-	See below: ART_INHABER_GESCH L	Type of unit holder for closed-end investment fund (in euro) (can be repeated as often as required)
--------------------	---	---	---

ART_MITTELANLAGE	+	Code table art_mittel	Type of investment fund according to nature of investment (excluding umbrella funds)
------------------	---	--------------------------	--

or

ART_MITTELANLAGE_D ACHFONDS	+	Code table art_mittel	Type of investment fund according to nature of investment: umbrella fund; here: investment focus
--------------------------------	---	--------------------------	--

ART_ERTRAG	+	Code table art_ertrag	Type of investment fund according to income use
ART_LAUFZEIT	+	See below: ART_LAUFZEIT	Type of investment fund according to maturity
ART_RUECKNAHME	+	Code table ruecknahmeart	Type of unit redemption
fruehestens_ nach_x_Jahren		integer15pos	Minimum holding period up to earliest possible unit redemption in years
AUSSETZUNG	+	jjjjmmtt_nichtzutreffend	Date (YYYY-MM-DD) if unit redemption has been suspended. Otherwise, "nicht zutreffend" ("Not applicable").
NOTIERUNG	+	Code table notierung	Quotation type for fund units
INDEX	+	See below: INDEX	Index funds
WERTGESICHERT	+	bbk:jaNein	Indicator of whether fund is guaranteed
MASTER_FEEDER_STRUKTUR	+	See below: MASTER_FEEDER_STRUKTUR	Master-feeder structure
UEBERGEORDNET	+	See below: UEBERGEORDNET	Identifier of superordinated fund (if applicable)
GEOGR_FOKUS	+	Code table geogr_fokus	Geographical focus of investment fund
RENTEN_FOKUS	+	Code table renten_fokus	Investment focus if investment fund is a bond fund

IMMO_FOKUS	+	Code table immo_fokus	Investment focus if investment fund is a real estate fund
ESG_TYP	+	Code table esg_typ	ESG type

Sub-elements

GESELLSCHAFT

Information on company:

BAFIN-ID	+	bafin_id	
LEI	+	lei	
NAME	+	datatypeD_1_150	Name of company
ANSCHRIFT	+		Address of company
STRASSE	+	datatypeB_1_80	Street of company
PLZ	+	upperAlphanumeric, 1-20 characters	Postal code of company
ORT	+	datatypeB_1_80	Town/city of company
LAND	+	isoLand	Country of domicile of company

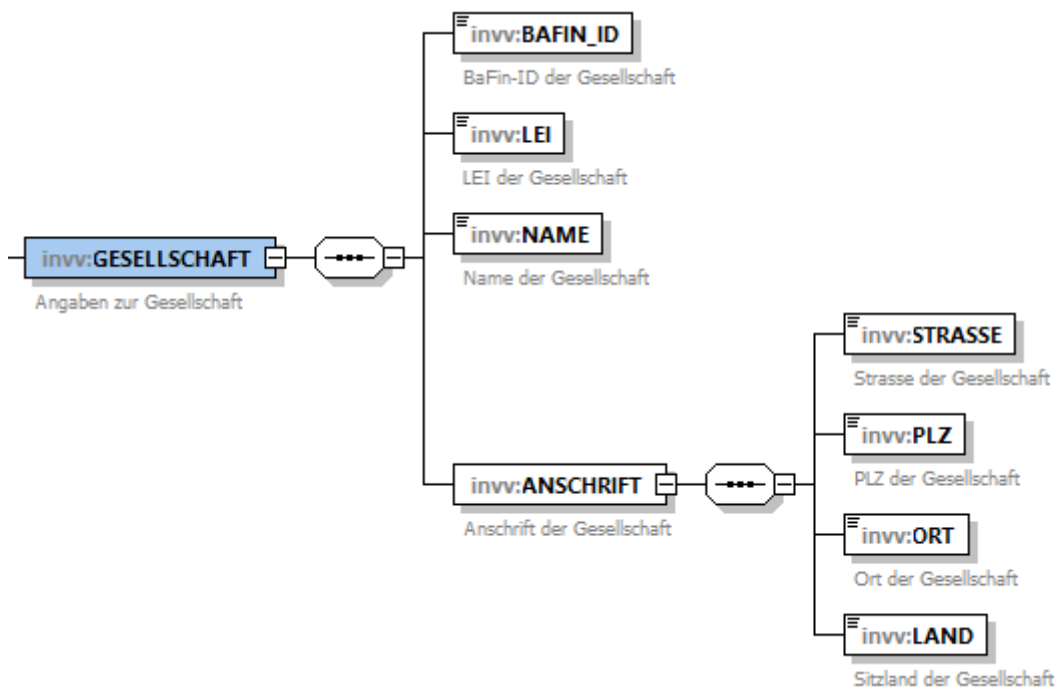

ERSTMELDUNG

Data from V10390:

DATUM	+	jjjjmmtt	Date of launch (YYYY-MM-DD)
GRUND	+		One entry only: NEUAUFLAGE or UEBERNAHME

NEUAUFLAGE	+	text0	Blank element for launch
------------	---	-------	--------------------------

or

UEBERNAHME	+	gesellschaftIsin NameLand	ISIN of investment fund before takeover as well as name and country of domicile of company that originally launched the investment fund
------------	---	------------------------------	--

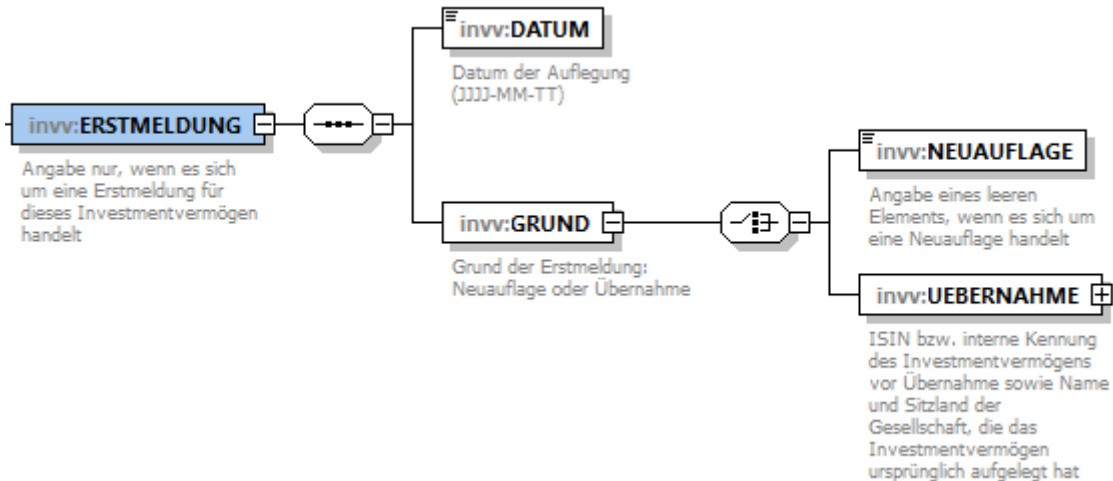

AENDERUNGSMELDUNG

Data from V10390:

DATUM	+	jjjjmmtt	Date of change (YYYY-MM-DD)
-------	---	----------	-----------------------------

LETZTMELDUNG

Data from V10390:

DATUM	+	jjjjmmtt	Date of resolution, transfer, merger or other (YYYY-MM-DD)
GRUND	+		One entry only: ABWICKLUNG or UEBERTRAGUNG or VERSCHMELZUNG
ABWICKLUNG	+	text0	Blank element for resolution

or

UEBERTRAGUNG	+	gesellschaftNameLand	Name and country of domicile of receiving company
--------------	---	----------------------	---

or (can be repeated as often as required for a merger with multiple investment funds)

VERSCHMELZUNG	+	gesellschaftIsinNameLand	ISIN or internal identifier of investment fund before merger as well as name and country of domicile of company with whose investment fund it is merged
---------------	---	--------------------------	--

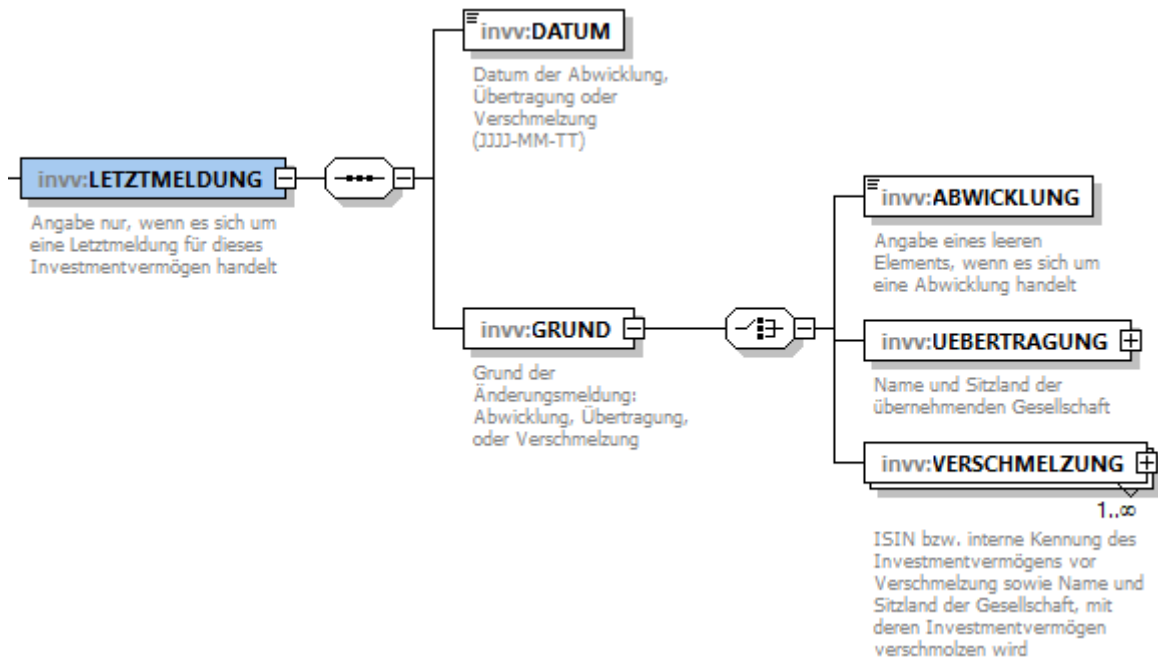

ART_INHABER_GESCHL

Information on the item “ART_INHABER_GESCHL” from V10390:

ANGABEN	+		(can be repeated as often as required)
BETRAG	+	integer15pos	Amount in euro
LAND	+	isoLand	Country of domicile of unit holder
SEKTOR	+	Code table sektor	Sector of unit holder

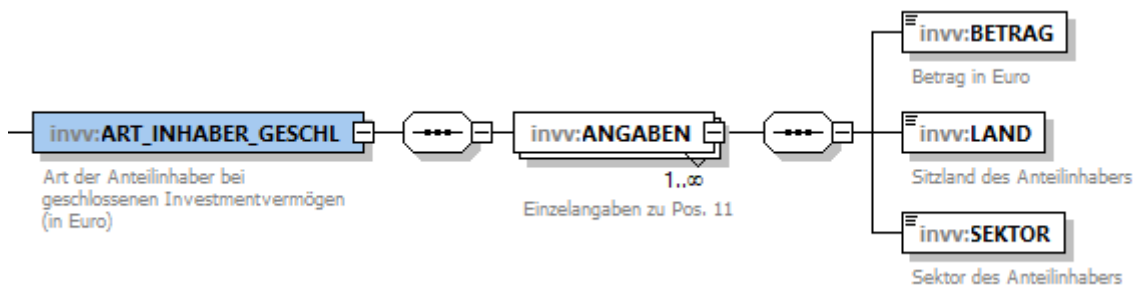

ART_LAUFZEIT

Information on the item “ART_LAUFZEIT” from V10390:

UNBEFRISTET	+	text0	Blank element if term is unlimited
or			
BEFRISTET	+	xs:gYearMonth	Date (YYYY-MM) if term is limited

Figure 4-2

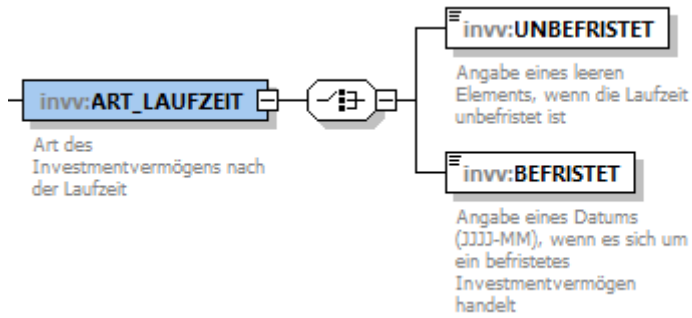

INDEX

Information on the item "INDEX" from V10390:

INDEXFONDS_NEIN	+	text0	Entry (blank element) if investment fund is not an index fund
-----------------	---	-------	---

or

INDEXFONDS_JA	+		Entry if investment fund is an index fund
BOERSENGEHANDELT	+	bbk:jaNein	Indicator of whether index fund is traded on an exchange
INDEXABB	+	Schlüsseltabelle index_abbildung	Type of index replication
ABGEBILDETER_INDEX	+		Replicated index
ISIN	+	isin	ISIN of replicated index

or

TEXT	+	datatypeE_1_40	Text entry for replicated index if index does not have an ISIN
------	---	----------------	--

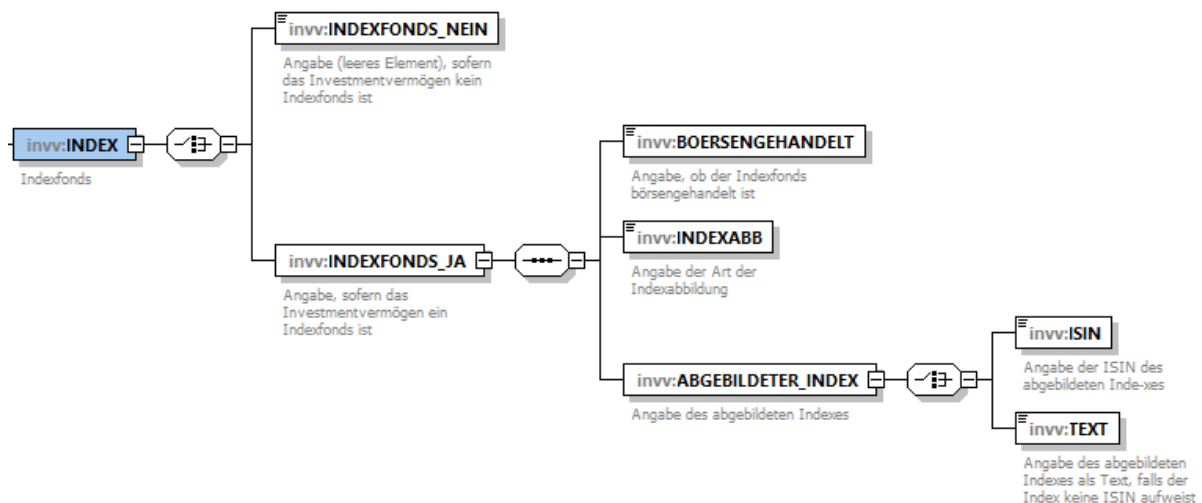

MASTER_FEEDER_STRUKTUR

Information on the item “MASTER_FEEDER_STRUKTUR” from V10390:

Identifier of all related feeders if report is for master (can be repeated as often as required):

FEEDER_ISIN	+	isin	
-------------	---	------	--

or

FEEDER_INTERNE_KNR	+	interne_knr	
--------------------	---	-------------	--

Identifier of related master if report is for feeder (one entry only):

MASTER_ISIN	+	isin	
-------------	---	------	--

or

MASTER_INTERNE_KNR	+	interne_knr	
--------------------	---	-------------	--

Entry if fund is neither master nor feeder:

KEIN_MASTER_BZW_FEEDER_VORHANDEN	+	text0	Blank element
----------------------------------	---	-------	---------------

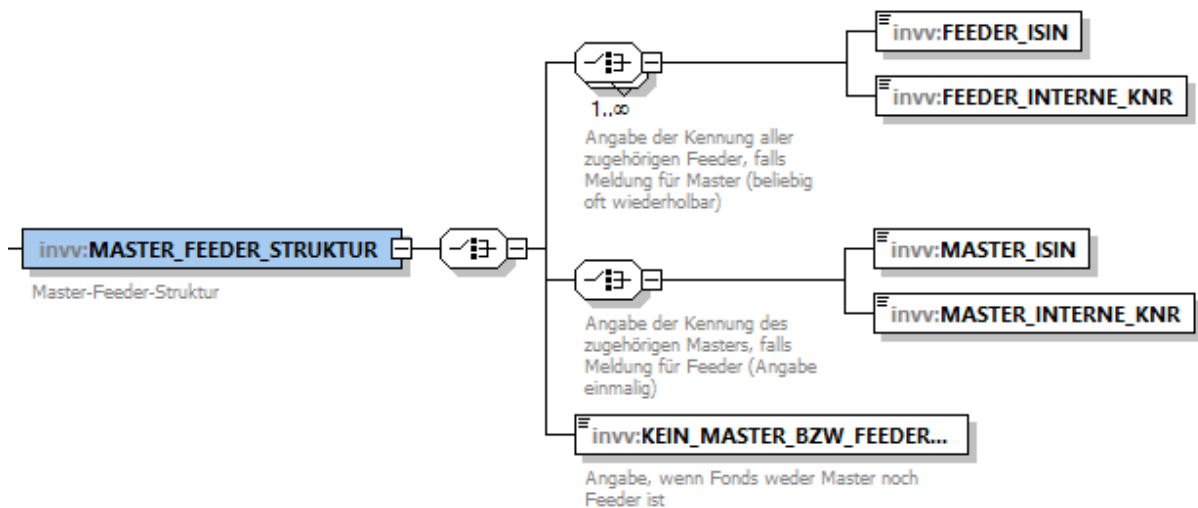

UEBERGEORDNET

Information on the item “UEBERGEORDNET” from V10390:

Identifier of the superordinated investment fund if report is for unit class:

ANTEILSKLASSE	+		
---------------	---	--	--

UEBERGEORDNETE_ISIN	+	isin	
---------------------	---	------	--

or

UEBERGEORDNETE_INTERNE_KNR	+	interne_knr	
----------------------------	---	-------------	--

Identifier of the superordinated investment fund if report is for sub-fund:

TEILINVV	+		
----------	---	--	--

UEBERGEORDNETE_ISIN	+	isin	
---------------------	---	------	--

or

UEBERGEORDNETE_INTERNE_KNR	+	interne_knr	
----------------------------	---	-------------	--

Identifier of the superordinated (umbrella) investment fund if report is for special-purpose entity:

OBJEKTGESELLSCHAFT	+		
UEBERGEORDNETE_ISIN	+	isin	

or

UEBERGEORDNETE_INTERNE_KNR	+	interne_knr	
----------------------------	---	-------------	--

Entry if no superordinated fund exists:

KEIN_UEBERGEORDNETER_FONDS_V ORHANDEN	+	text0	Blank element
--	---	-------	---------------

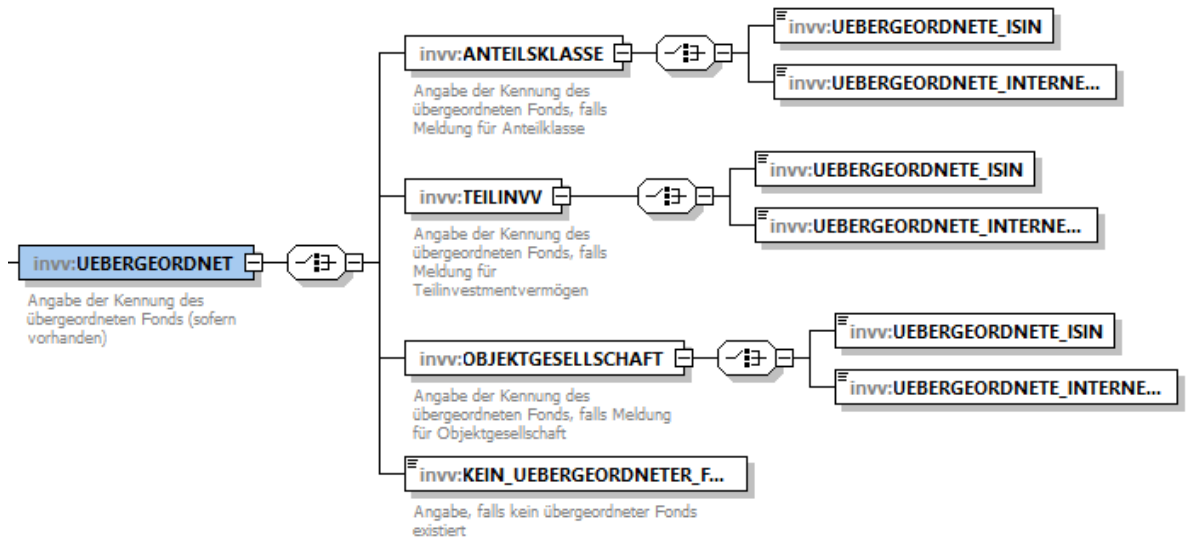

Example

```

<ALLGEMEIN_INVV>
  <BBK_INSTITUTS_ID>00123</BBK_INSTITUTS_ID>
  <INVV_NAME>Beispiel-Investmentvermoegen 1</INVV_NAME>
  <ISIN>DE00012BSP01</ISIN>
  <GESELLSCHAFT>
    <BAFIN_ID>unbekannt</BAFIN_ID>
    <LEI>unbekannt</LEI>
    <NAME>Beispiel-Gesellschaft</NAME>
    <ANSCHRIFT>
      <STRASSE>ABC-Straße 1</STRASSE>
      <PLZ>12345</PLZ>
      <ORT>Beispiel-Ort</ORT>
      <LAND>DE</LAND>
    </ANSCHRIFT>
  </GESELLSCHAFT>
  <RECHT>DE</RECHT>
  <BAFIN_ID>unbekannt</BAFIN_ID>
  <LEI>123400A1B2C3D4E5F699</LEI>
  <ERSTMELDUNG>
    <DATUM>2012-01-15</DATUM>
    <GRUND>
      <NEUAUFLAGE/>
    </GRUND>
  </ERSTMELDUNG>
  <ORGANISATION>offen - Sondervermoegen</ORGANISATION>
  <TYP>Spezial-AIF - Offener Spezial-AIF - Allgemeiner offener Spezial-AIF</TYP>
  <ART_INHABER_OFFEN>Lebensversicherungen</ART_INHABER_OFFEN>
  <ART_MITTELANLAGE>Aktienfonds</ART_MITTELANLAGE>
  <ART_ERTRAG>Thesaurierungsfonds</ART_ERTRAG>
  <ART_LAUFZEIT>
    <UNBEFRISTET/>
  </ART_LAUFZEIT>
  <ART_RUECKNAHME fruehestens_nach_x_Jahren="7">halbjaehrlich</ART_RUECKNAHME>
  <AUSSETZUNG>2025-07-31</AUSSETZUNG>
  <NOTIERUNG>stuecknotiert</NOTIERUNG>
  <INDEX>
    <INDEXFONDS_JA>
      <BOERSENGEHANDELT>nein</BOERSENGEHANDELT>
      <INDEXABB>physisch - vollstaendige Abbildung</INDEXABB>
      <ABGEBILDETER_INDEX>
        <ISIN>DE000INDEX01</ISIN>
      </ABGEBILDETER_INDEX>
    </INDEXFONDS_JA>
  </INDEX>
  <WERTGESICHERT>nein</WERTGESICHERT>
  <MASTER_FEEDER_STRUKTUR>
    <FEEDER_ISIN>DE00034BSP01</FEEDER_ISIN>
    <FEEDER_INTERNE_KNR>98765</FEEDER_INTERNE_KNR>
  </MASTER_FEEDER_STRUKTUR>
  <UEBERGEORDNET>
    <ANTEILSKLASSE>
      <UEBERGEORDNETE_ISIN>XC00012BSP01</UEBERGEORDNETE_ISIN>
    </ANTEILSKLASSE>
  </UEBERGEORDNET>
  <GEOGR_FOKUS>Suedamerika</GEOGR_FOKUS>
  <RENTEN_FOKUS>Gemischt</RENTEN_FOKUS>
  <IMMO_FOKUS>Kein Immofokus</IMMO_FOKUS>
  <ESG_TYP>SFDR Artikel 8 konform</ESG_TYP>
</ALLGEMEIN_INVV>

```

4.4.2 MONATLICH_INVV (V10391)

The monthly reports for individual investment funds must be submitted by the fifth business day of the month following the reporting month.

Unless otherwise stated, reports must relate to the status as at the end of the reporting month (last day).

For superordinated funds, reports must be submitted separately for each unit class and for each sub-fund.

In addition to the amount of fund assets, all non-financial and financial asset and liabilities positions – where available – must be stated separately, including their sub-categories according to type, maturity, sector and country.

Information on held securities must be submitted separately for each security (security-for-security reporting system).

Elements

Name	Req	Value range/format	Comments
	.		
(Form header)	+	formular_kopf	Bundesbank institution ID, name and identifier of investment fund
WERTPAPIERE_MIT_ISIN	-	wpMitISIN	Individual securities with an ISIN (in euro or number of units)
WERTPAPIERE_OHNE_ISIN	-	wpOhneISIN	Individual securities without an ISIN (in euro or number of units)
BANKGUTHABEN	-	bankguthaben	Bank deposits (in euro)
KRYPTOWERTE	-	kryptowerte	Crypto-assets (in euro)
DARL_IMMO_GES	-	forderungen	Loans to real estate companies (in euro)
SCHULDSCHEINDARLEHEN	-	forderungen	Borrowers' note loans (in euro)
UNVERBR_DARL_FORD	-	forderungen	Unsecuritised loan receivables (in euro)
FORD_WP_LEIH_GESCH	-	forderungen	Receivables from securities lending and repurchase transactions (in euro)
SONST_FORDERUNGEN	-	forderungen	Other receivables (in euro)
GRUNDSTUECKE_UNBEBAUT	-	nf_vermoegen	Undeveloped land (in euro)
GRUNDSTUECKE_BEBAUT	-	nf_vermoegen_grundst_beb	Developed land (in euro)
SCHIFFE	-	nf_vermoegen	Ships, superstructures of ships and ship components and replacement parts (in euro)
CONTAINER	-	nf_vermoegen	Containers (in euro)

LUFTFAHRZEUGE	-	nf_vermoegen	Aircraft, aircraft components and replacement parts (in euro)
ENERGIE_ANLAGEN	-	nf_vermoegen	Facilities for the generation, transportation and storage of energy (in thousand euro)
SONSTIGE_NF_VERM	-	nf_vermoegen	Other non-financial assets (in euro)
BETEILIGUNG_IMMOGESELLSCHAFT	-	beteiligungen	Participating interests in real estate companies (in euro)
BETEILIGUNG_OEPP	-	beteiligungen	Participating interests in PPP project companies (in euro)
BETEILIGUNG_SONST	-	beteiligungen	Participating interests in other companies (in euro)
DERIVATE_AKTIVA	-	derivate	Financial derivatives (assets) (in euro)
SONSTIGES_VERMOEGEN	-	sonst_vermoegen	Other assets (in euro)
KREDITE	-	verbindlichkeiten	Borrowing (in euro)
VERB_WP_LEIH_GESCH	-	verbindlichkeiten	Liabilities from securities lending and repurchase transactions (in euro)
DERIVATE_PASSIVA	-	derivate	Financial derivatives (liabilities) (in euro)
SONSTIGE_VERBINDLICHKEITEN	-	sonst_verbindlichkeiten	Other liabilities (in euro)
FONDSVERMOEGEN	+	integer15	Fund assets (in euro)
NOTIERUNG	+	See below: NOTIERUNG	Entry dependent on quotation type for investment fund
MITTELZUFLUESSE	+	integer15pos	Inflows from sale of fund units (in euro)
MITTELABFLUESSE	+	integer15pos	Outflows from repurchase of fund units (in euro)
ERTRAGSAUSSCHUETTUNG	+	integer15pos	Total amount of earnings distribution (in euro)
ERLOESE_VERMPOS	-	erl_vermpos	Sales proceeds from sold properties of various assets during reporting month (in euro)
GEBUEHREN	+	integer15pos	Fees paid by investment fund (in euro)
EINNAHMEN_VERMOEGEN	+	integer15pos	Payments received from assets (excluding securities)

Sub-elements
QUOTATION

STUECKNOTIERT	+	Information on investment fund assets quoted in number of units	
UMLAUF_STUECKZAHL	+	doublePos	Units outstanding (number of units)
AUSGABE_PREIS	+	doublePos	Issue price per unit (in euro, at least 2 decimal places)
RUECKNAHME_PREIS	+	doublePos	Redemption price per unit (in euro, at least 2 decimal places)
BRUTTOABSATZ_ STUECKZAHL	+	doublePos	Gross sales (number of units)

or

PROZENTNOTIERT	+	Information on investment fund assets quoted as a percentage	
UMLAUF_NOMINALWERT	+	doublePos	Amount outstanding (nominal, in euro)
AUSGABE_KURS	+	doublePos	Issue price (as a percentage, at least three decimal places)
RUECKNAHME_KURS	+	doublePos	Redemption price (as a percentage, at least three decimal places)
BRUTTOABSATZ_ NOMINALWERT	+	doublePos	Gross sales (nominal, in euro)

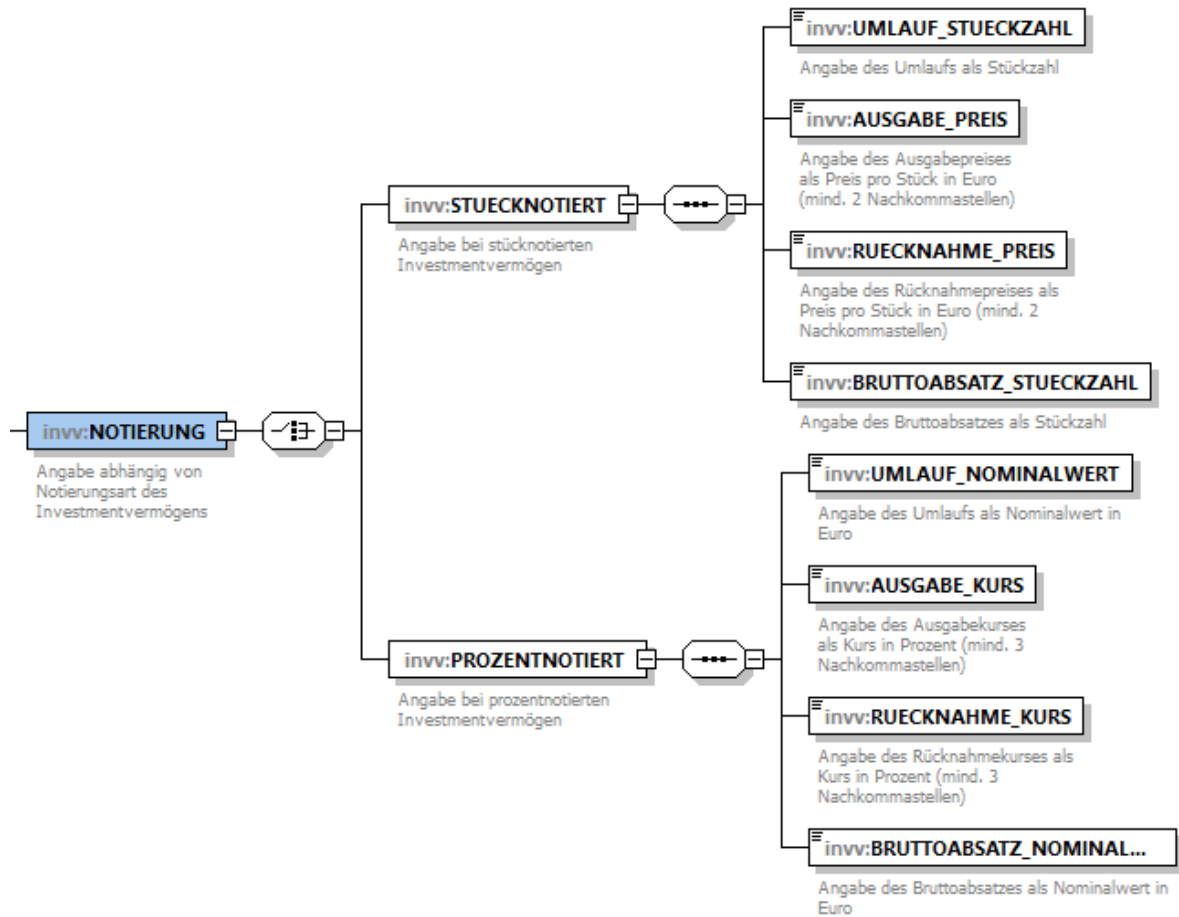

Example

Focus on securities:

```

<MONATLICH_INVV>
  <BBK_INSTITUTS_ID>00123</BBK_INSTITUTS_ID>
  <INVV_NAME>Beispiel Wertpapierfonds</INVV_NAME>
  <ISIN>DE00012BSP01</ISIN>
  <WERTPAPIERE_MIT_ISIN>
    <ANGABEN>
      <ISIN>DE000123WP01</ISIN>
      <NOMINALWERT>100000</NOMINALWERT>
      <KURS>99.050</KURS>
      <WAEHRUNG>EUR</WAEHRUNG>
      <DARUNTER_WP_LEIHG>6000</DARUNTER_WP_LEIHG>
      <DARUNTER_ECHTE_PG>4000</DARUNTER_ECHTE_PG>
    </ANGABEN>
  </WERTPAPIERE_MIT_ISIN>
  <WERTPAPIERE_OHNE_ISIN>
    <ANGABEN>
      <ISIN>DE000123WP02</ISIN>
      <STUECKZAHL>10000</STUECKZAHL>
      <PREIS>70.50</PREIS>
      <WAEHRUNG>USD</WAEHRUNG>
      <DARUNTER_WP_LEIHG>0</DARUNTER_WP_LEIHG>
      <DARUNTER_ECHTE_PG>0</DARUNTER_ECHTE_PG>
    </ANGABEN>
  </WERTPAPIERE_OHNE_ISIN>
  <ANGABEN>
    <INTERNE_WP_KNR>DE000123WP03</INTERNE_WP_KNR>
    <WERTPAPIERART>kurzfristige Schuldverschreibung (F.31)</WERTPAPIERART>
    <EMITTENTENCODE>BLZ</EMITTENTENCODE>
  </ANGABEN>

```

```

    <EMITTENTENNAME>Emittent1</EMITTENTENNAME>
    <EMITTENTENLAND>AT</EMITTENTENLAND>
    <EMITTENTENSEKTOR>Kredit- und Versicherungshilfstätigkeiten
(S.126)</EMITTENTENSEKTOR>
    <EMISSIONSDATUM>2012-01-31</EMISSIONSDATUM>
    <FAELLIGKEIT>2017-05-22</FAELLIGKEIT>
    <ZINS>1.75</ZINS>
    <NOMINALWERT>100000</NOMINALWERT>
    <KURS>101.010</KURS>
    <WAEHRUNG>EUR</WAEHRUNG>
    <DARUNTER_WP_LEIHG>0</DARUNTER_WP_LEIHG>
    <DARUNTER_ECHTE_PG>0</DARUNTER_ECHTE_PG>
  </ANGABEN>
  <ANGABEN>
    <INTERNE_WP_KNR>DE000127WP03</INTERNE_WP_KNR>
    <WERTPAPIERART>Sonstiges Anteilsrecht (F.519)</WERTPAPIERART>
    <EMITTENTENCODE>BIC</EMITTENTENCODE>
    <EMITTENTENNAME>Emittent2</EMITTENTENNAME>
    <EMITTENTENLAND>GB</EMITTENTENLAND>
    <EMITTENTENSEKTOR>Nichtfinanzielle Kapitalgesellschaften
(S.11)</EMITTENTENSEKTOR>
    <EMISSIONSDATUM>2012-01-01</EMISSIONSDATUM>
    <FAELLIGKEIT>nicht zutreffend</FAELLIGKEIT>
    <ZINS>2.555</ZINS>
    <STUECKZAHL>1000</STUECKZAHL>
    <PREIS>65.90</PREIS>
    <WAEHRUNG>GBP</WAEHRUNG>
    <DARUNTER_WP_LEIHG>0</DARUNTER_WP_LEIHG>
    <DARUNTER_ECHTE_PG>0</DARUNTER_ECHTE_PG>
  </ANGABEN>
</WERTPAPIERE_OHNE_ISIN>
<BANKGUTHABEN>
  <ANGABEN>
    <BETRAG>3000</BETRAG>
    <WAEHRUNG>EUR</WAEHRUNG>
    <LAND>DE</LAND>
    <SEKTOR>Kreditinstitute (S.122)</SEKTOR>
    <FRISTIGKEIT>taeglich</FRISTIGKEIT>
  </ANGABEN>
</BANKGUTHABEN>
<FORD_WP_LEIH_GESCH>
  <ANGABEN>
    <BETRAG>50</BETRAG>
    <WAEHRUNG>EUR</WAEHRUNG>
    <LAND>DE</LAND>
    <SEKTOR>Kreditinstitute (S.122)</SEKTOR>
    <FRISTIGKEIT>bis 1 Monat</FRISTIGKEIT>
    <VERBUNDENES_UNTERNEHMEN>nein</VERBUNDENES_UNTERNEHMEN>
  </ANGABEN>
</FORD_WP_LEIH_GESCH>
<DERIVATE_AKTIVA>
  <ANGABEN>
    <BETRAG>30</BETRAG>
    <TRANSAKTIONEN_VOLUMEN>15</TRANSAKTIONEN_VOLUMEN>
    <LAND>US</LAND>
  </ANGABEN>
</DERIVATE_AKTIVA>
<SONSTIGES_VERMOEGEN>
  <GESAMTBETRAG>500</GESAMTBETRAG>
  <ZINSEN_EINLAGEN>300</ZINSEN_EINLAGEN>
  <ZINSEN_WERTPAPIERE>100</ZINSEN_WERTPAPIERE>
  <FORDERUNGEN>50</FORDERUNGEN>
</SONSTIGES_VERMOEGEN>
<DERIVATE_PASSIVA>
  <ANGABEN>
    <BETRAG>30</BETRAG>
    <TRANSAKTIONEN_VOLUMEN>15</TRANSAKTIONEN_VOLUMEN>

```

```
<LAND>US</LAND>
</ANGABEN>
</DERIVATE_PASSIVA>
<SONSTIGE_VERBINDLICHKEITEN>
  <GESAMTBETRAG>100</GESAMTBETRAG>
  <ZINSEN_AUFGELAUFEN>20</ZINSEN_AUFGELAUFEN>
</SONSTIGE_VERBINDLICHKEITEN>
<FONDSVERMOEGEN>4441</FONDSVERMOEGEN>
<NOTIERUNG>
  <STUECKNOTIERT>
    <UMLAUF_STUECKZAHL>100000</UMLAUF_STUECKZAHL>
    <AUSGABE_PREIS>46.63</AUSGABE_PREIS>
    <RUECKNAHME_PREIS>44.41</RUECKNAHME_PREIS>
    <BRUTTOABSATZ_STUECKZAHL>50</BRUTTOABSATZ_STUECKZAHL>
  </STUECKNOTIERT>
</NOTIERUNG>
<MITTELZUFUESSE>2</MITTELZUFUESSE>
<MITTELABFLUESSE>5</MITTELABFLUESSE>
<ERTRAGSAUSSCHUETTUNG>40</ERTRAGSAUSSCHUETTUNG>
<GEBUEHREN>100</GEBUEHREN>
<EINNAHMEN_VERMOEGEN>10</EINNAHMEN_VERMOEGEN>
</MONATLICH_INVV>
```

Focus on real estate:

```
<MONATLICH_INVV>
  <BBK_INSTITUTS_ID>00123</BBK_INSTITUTS_ID>
  <INVV_NAME>Beispiel Immobilienfonds</INVV_NAME>
  <INTERNE_KNR>13245</INTERNE_KNR>
  <BANKGUTHABEN>
    <ANGABEN>
      <BETRAG>3000</BETRAG>
      <WAEHRUNG>EUR</WAEHRUNG>
      <LAND>DE</LAND>
      <SEKTOR>Kreditinstitute (S.122)</SEKTOR>
      <FRISTIGKEIT>taeglich</FRISTIGKEIT>
    </ANGABEN>
    <ANGABEN>
      <BETRAG>2000</BETRAG>
      <WAEHRUNG>EUR</WAEHRUNG>
      <LAND>DE</LAND>
      <SEKTOR>Kreditinstitute (S.122)</SEKTOR>
      <FRISTIGKEIT>ueber 6 Monate bis 1 Jahr</FRISTIGKEIT>
    </ANGABEN>
    <ANGABEN>
      <BETRAG>2000</BETRAG>
      <WAEHRUNG>GBP</WAEHRUNG>
      <LAND>GB</LAND>
      <SEKTOR>Kreditinstitute (S.122)</SEKTOR>
      <FRISTIGKEIT>ueber 3 Monate bis 6 Monate</FRISTIGKEIT>
    </ANGABEN>
    <ANGABEN>
      <BETRAG>1000</BETRAG>
      <WAEHRUNG>USD</WAEHRUNG>
      <LAND>DE</LAND>
      <SEKTOR>Kreditinstitute (S.122)</SEKTOR>
      <FRISTIGKEIT>bis 1 Monat</FRISTIGKEIT>
    </ANGABEN>
  </BANKGUTHABEN>
  <DARL_IMMO_GES>
    <ANGABEN>
```



```

        <BETRAG>100</BETRAG>
        <WAEHRUNG>EUR</WAEHRUNG>
        <LAND>DE</LAND>
        <SEKTOR>Nichtfinanzielle Kapitalgesellschaften (S.11)</SEKTOR>
        <FRISTIGKEIT>ueber 5 Jahre bis 10 Jahre</FRISTIGKEIT>
        <VERBUNDENES_UNTERNEHMEN>ja</VERBUNDENES_UNTERNEHMEN>
    </ANGABEN>
</DARL_IMMO_GES>
<GRUNDSTUECKE_UNBEBAUT>
    <ANGABEN>
        <BETRAG>1000</BETRAG>
        <LAND>FR</LAND>
        <OBJEKTID>GRUNDST1</OBJEKTID>
    </ANGABEN>
</GRUNDSTUECKE_UNBEBAUT>
<GRUNDSTUECKE_BEBAUT>
    <ANGABEN>
        <BETRAG>3000</BETRAG>
        <LAND>DE</LAND>
        <NUTZUNGSART>Buero</NUTZUNGSART>
        <OBJEKTID>GRUNDST2</OBJEKTID>
    </ANGABEN>
    <ANGABEN>
        <BETRAG>1500</BETRAG>
        <LAND>DE</LAND>
        <NUTZUNGSART>Wohnen</NUTZUNGSART>
        <OBJEKTID>GRUNDST3</OBJEKTID>
    </ANGABEN>
    <ANGABEN>
        <BETRAG>500</BETRAG>
        <LAND>IT</LAND>
        <NUTZUNGSART>Buero</NUTZUNGSART>
        <OBJEKTID>GRUNDST4</OBJEKTID>
    </ANGABEN>
</GRUNDSTUECKE_BEBAUT>
<BETEILIGUNG_IMMOGESELLSCHAFT>
    <ANGABEN>
        <BETRAG>2000</BETRAG>
        <LAND>US</LAND>
        <OBJEKTID>IMMO1</OBJEKTID>
    </ANGABEN>
</BETEILIGUNG_IMMOGESELLSCHAFT>
<SONSTIGES_VERMOEGEN>
    <GESAMTBETRAG>200</GESAMTBETRAG>
    <FORDERUNGEN>100</FORDERUNGEN>
</SONSTIGES_VERMOEGEN>
<KREDITE>
    <ANGABEN>
        <BETRAG>300</BETRAG>
        <WAEHRUNG>EUR</WAEHRUNG>
        <LAND>NL</LAND>
        <SEKTOR>Kreditinstitute (S.122)</SEKTOR>
        <FRISTIGKEIT>ueber 5 Jahre bis 10 Jahre</FRISTIGKEIT>
        <MINDESTRESERVEPFL_INST>ja</MINDESTRESERVEPFL_INST>
    </ANGABEN>
    <ANGABEN>
        <BETRAG>200</BETRAG>
        <WAEHRUNG>EUR</WAEHRUNG>
        <LAND>DE</LAND>
        <SEKTOR>Kreditinstitute (S.122)</SEKTOR>
    
```

```
<FRISTIGKEIT>ueber 3 Jahre bis 4 Jahre</FRISTIGKEIT>
<MINDESTRESERVEPFL_INST>nein</MINDESTRESERVEPFL_INST>
</ANGABEN>
</KREDITE>
<SONSTIGE_VERBINDLICHKEITEN>
  <GESAMTBETRAG>20</GESAMTBETRAG>
</SONSTIGE_VERBINDLICHKEITEN>
<FONDSVERMOEGEN>15780</FONDSVERMOEGEN>
<NOTIERUNG>
  <PROZENTNOTIERT>
    <UMLAUF_NOMINALWERT>100</UMLAUF_NOMINALWERT>
    <AUSGABE_KURS>20</AUSGABE_KURS>
    <RUECKNAHME_KURS>100.00</RUECKNAHME_KURS>
    <BRUTTOABSATZ_NOMINALWERT>50</BRUTTOABSATZ_NOMINALWERT>
  </PROZENTNOTIERT>
</NOTIERUNG>
<MITTELZUFLUESSE>6</MITTELZUFLUESSE>
<MITTELABFLUESSE>0</MITTELABFLUESSE>
<ERTRAGSAUSSCHUETTUNG>500</ERTRAGSAUSSCHUETTUNG>
<GEBUEHREN>100</GEBUEHREN>
<EINNAHMEN_VERMOEGEN>20</EINNAHMEN_VERMOEGEN>
</MONATLICH_INVV>
```

Focus on ships:

```
<MONATLICH_INVV>
  <BBK_INSTITUTS_ID>00123</BBK_INSTITUTS_ID>
  <INVV_NAME>Beispiel Schiffsfonds</INVV_NAME>
  <ISIN>DE00012BSP03</ISIN>
  <BANKGUTHABEN>
    <ANGABEN>
      <BETRAG>5000</BETRAG>
      <WAEHRUNG>EUR</WAEHRUNG>
      <LAND>DE</LAND>
      <SEKTOR>Kreditinstitute (S.122)</SEKTOR>
      <FRISTIGKEIT>taeglich</FRISTIGKEIT>
    </ANGABEN>
  </BANKGUTHABEN>
  <ANGABEN>
    <BETRAG>3000</BETRAG>
    <WAEHRUNG>EUR</WAEHRUNG>
    <LAND>DE</LAND>
    <SEKTOR>Kreditinstitute (S.122)</SEKTOR>
    <FRISTIGKEIT>ueber 6 Monate bis 1 Jahr</FRISTIGKEIT>
  </ANGABEN>
</BANKGUTHABEN>
<SCHIFFE>
  <ANGABEN>
    <BETRAG>12000</BETRAG>
    <LAND>DE</LAND>
    <OBJEKTID>SCHIFF1</OBJEKTID>
  </ANGABEN>
  <ANGABEN>
    <BETRAG>10000</BETRAG>
    <LAND>PL</LAND>
    <OBJEKTID>SCHIFF2</OBJEKTID>
  </ANGABEN>
  <ANGABEN>
    <BETRAG>8000</BETRAG>
    <LAND>CN</LAND>
    <OBJEKTID>SCHIFF3</OBJEKTID>
  </ANGABEN>
</SCHIFFE>
<SONSTIGE_NF_VERM>
  <ANGABEN>
```

```

        <BETRAG>300</BETRAG>
        <LAND>DK</LAND>
        <OBJEKTID>BOOT1</OBJEKTID>
    </ANGABEN>
    <ANGABEN>
        <BETRAG>200</BETRAG>
        <LAND>IE</LAND>
        <OBJEKTID>BOOT2</OBJEKTID>
    </ANGABEN>
</SONSTIGE_NF_VERM>
<KREDITE>
    <ANGABEN>
        <BETRAG>8000</BETRAG>
        <WAEHRUNG>EUR</WAEHRUNG>
        <LAND>NL</LAND>
        <SEKTOR>Kreditinstitute (S.122)</SEKTOR>
        <FRISTIGKEIT>ueber 5 Jahre bis 10 Jahre</FRISTIGKEIT>
        <MINDESTRESERVEPFL_INST>ja</MINDESTRESERVEPFL_INST>
    </ANGABEN>
    <ANGABEN>
        <BETRAG>3000</BETRAG>
        <WAEHRUNG>EUR</WAEHRUNG>
        <LAND>DE</LAND>
        <SEKTOR>Kreditinstitute (S.122)</SEKTOR>
        <FRISTIGKEIT>ueber 5 Jahre bis 10 Jahre</FRISTIGKEIT>
        <MINDESTRESERVEPFL_INST>nein</MINDESTRESERVEPFL_INST>
    </ANGABEN>
    <ANGABEN>
        <BETRAG>1000</BETRAG>
        <WAEHRUNG>EUR</WAEHRUNG>
        <LAND>DE</LAND>
        <SEKTOR>Kreditinstitute (S.122)</SEKTOR>
        <FRISTIGKEIT>ueber 3 Jahre bis 4 Jahre</FRISTIGKEIT>
        <MINDESTRESERVEPFL_INST>nein</MINDESTRESERVEPFL_INST>
    </ANGABEN>
</KREDITE>
<FONDSVERMOEGEN>26500</FONDSVERMOEGEN>
<NOTIERUNG>
    <STUECKNOTIERT>
        <UMLAUF_STUECKZAHL>5</UMLAUF_STUECKZAHL>
        <AUSGABE_PREIS>100</AUSGABE_PREIS>
        <RUECKNAHME_PREIS>90</RUECKNAHME_PREIS>
        <BRUTTOABSATZ_STUECKZAHL>100</BRUTTOABSATZ_STUECKZAHL>
    </STUECKNOTIERT>
</NOTIERUNG>
<MITTELZUFLUESSE>80</MITTELZUFLUESSE>
<MITTELABFLUESSE>1500</MITTELABFLUESSE>
<ERTRAGSAUSSCHUETTUNG>750</ERTRAGSAUSSCHUETTUNG>
<GEBUEHREN>20</GEBUEHREN>
<EINNAHMEN_VERMOEGEN>100</EINNAHMEN_VERMOEGEN>
</MONATLICH_INVV>
    
```

5 Annex

5.1 Code table organisationsform

XML element: ORGANISATION

Code list: Organisational form of the investment fund

XML schema
offen - Sondervermoege n (Open - specialised fund)
offen - Investmentaktiengesellschaft mit veraenderlichem Kapital (Open - investment stock corporation with changeable capital)
offen - Investmentkommanditgesellschaft (Open – investment limited partnership)
geschlossen - Sondervermoege n (Closed - specialised fund)
geschlossen - Investmentaktiengesellschaft mit fixem Kapital (Closed - investment stock corporation with fixed capital)
geschlossen - Investmentkommanditgesellschaft (Closed - investment limited partnership)

5.2 Code table typ

XML element: TYP

Code list: Type of investment fund

XML schema
Publikumsinvestmentvermoege n - Organismus fuer gemeinsame Anlagen in Wertpapieren (OGAW) (Investment fund open to the general public - Undertakings for Collective Investment in Transferable Securities (UCITS))
Publikumsinvestmentvermoege n - Offener Publikums-AIF - Gemischtes Investmentvermoege n (Investment fund open to the general public - open-end public AIF - mixed investment fund)
Publikumsinvestmentvermoege n - Offener Publikums-AIF - Sonstiges Investmentvermoege n (Investment fund open to the general public - open-end public AIF - other investment fund)
Publikumsinvestmentvermoege n - Offener Publikums-AIF - Dach-Hedgefonds (Investment fund open to the general public - open-end public AIF - fund of hedge funds)
Publikumsinvestmentvermoege n - Offener Publikums-AIF - Immobilien-Sondervermoege n (Investment fund open to the general public - open-end public AIF - specialised real estate fund)
Publikumsinvestmentvermoege n - Geschlossener Publikums-AIF (Investment fund open to the general public - closed-end public AIF)
Spezial-AIF - Offener Spezial-AIF - Allgemeiner offener Spezial-AIF (Specialised AIF - open-end specialised AIF - general open-end specialised AIF)

Spezial-AIF - Offener Spezial-AIF - Hedgefonds (Specialised AIF - open-end specialised AIF - hedge fund)
Spezial-AIF - Offener Spezial-AIF - Spezial-AIF mit festen Anlagebedingungen (Specialised AIF - open-end specialised AIF - specialised AIF with fixed investment conditions)
Spezial-AIF - Geschlossener Spezial-AIF (Specialised AIF - closed-end specialised AIF)
Weder OGAW noch AIF-konform (Neither UCITS nor AIF-compliant)

5.3 Code table art_inhaber_offen

XML element: ART_INHABER_OFFEN

Code list: Type of unit holder – open-end investment fund

XML schema
Kreditinstitute (Deposit-taking corporations)
Lebensversicherungen (Life insurance corporations)
andere Versicherungen (Other insurance corporations)
Altersvorsorgeeinrichtungen (Pension funds)
sonstige Finanzintermediaere (Other financial intermediaries)
Kredit- und Versicherungshilfsinstitutionen (Financial auxiliaries)
nichtfinanzielle Kapitalgesellschaften (Non-financial corporations)
Bund (Central government)
Laender (State government)
Gemeinden (Local government)
Sozialversicherungen (Social security funds)
oeffentliche und kirchliche Zusatzversorgungseinrichtungen (Public and church supplementary pension funds)
private Organisationen ohne Erwerbszweck und sonstige (Non-profit institutions serving households and other)
Auslaender (Non-residents)

5.4 Code table art_mittel

XML element: ART_MITTELANLAGE

Code list: Type of fund according to investment activity

XML schema
Aktiefonds (Equity fund)
Rentenfonds (Bond fund)

Gemischter Wertpapierfonds (Mixed securities-based fund)
Immobilienfonds (Real estate fund)
Geldmarktfonds (ohne Geldmarktfonds mit kurzer Laufzeitstruktur) (Money market fund (excl. money market fund with short maturity structure))
Geldmarktfonds mit kurzer Laufzeitstruktur (Money market fund with short maturity structure)
Hedgefonds (Hedge fund)
Derivatefonds (Derivatives fund)
Altersvorsorgefonds (Pension mutual fund)
Infrastrukturfonds (Infrastructure fund)
Rohstofffonds (Commodities fund)
Kreditfonds (Credit funds)
Schiffsfonds (Ship fund)
Flugzeugfonds (Aircraft fund)
Energiefonds (Energy fund)
Private Equity Fonds (ohne Venture Capital Fonds) (Private equity fund (excl. venture capital fund))
Venture Capital Fonds (Venture capital fund)
Leasingfonds (Leasing fund)
Kryptofonds (Crypto fund)
Sonstiger Fonds (Other fund)

5.5 Code table art_ertrag

XML element: ART_ERTRAG

Code list: Type of fund according to income use

XML schema
Ausschüttungsfonds (Distribution fund)
Thesaurierungsfonds (Accumulation fund)
Gemischte Ertragsverwendung (Mixed income use)

5.6 Code table notierung

XML element: NOTIERUNG

Code list: Quotation type for fund units

XML schema

stuecknotiert (Quoted in number of units)
prozentnotiert (Quoted as a percentage)

5.7 Code table ruecknahmeart

XML element: ART_RUECKNAHME

Code list: Type of redemption

XML schema
boersentaeglich (Every stock exchange trading day)
woechentlich (Weekly)
monatlich (Monthly)
quartalsweise (Quarterly)
halbjaehrlich (Semiannually)
jaehrlich (Yearly)
mindestens einmal waehrend der Laufzeit (ohne mindestens einmal jaehrlich) (At least once during the term (excluding at least once a year))
ausschliesslich am Laufzeitende beziehungsweise bei Abwicklung (Exclusively upon maturity or settlement)
sonstige (Other)

5.8 Code table index_abbildung

XML element: INDEXABB

Code list: Type of index replication

XML schema
physisch - vollstaendige Abbildung (Physical - full replication)
physisch - ausgewaehlte Teilmenge (Physical - partial replication)
synthetisch (Synthetic)

5.9 Code table nutzungsart

XML element: NUTZUNGSART

Code list: Type of use of developed land

XML schema
Buero (Office)
Handel/Gastronomie (Retail/Restaurant)

Industrie (Industry)
Hotel (Hotel)
Wohnen (Housing)
Sonstiges (Other)

5.10 Code table wpArt

XML element: WERTPAPIERART

Code list: Type of security according to European System of Accounts 2010 (ESA 2010)

XML schema
kurzfristige Schuldverschreibung (F.31) (Short-term debt securities (F.31))
langfristige Schuldverschreibung (F.32) (Long-term debt securities (F.32))
boersennotierte Aktie (F.511) (Listed shares (F.511))
nicht boersennotierte Aktie (F.512) (Unlisted shares (F.512))
sonstiges Anteilsrecht (F.519) (Other equity (F.519))
Geldmarktfonds (F.521) (Money market fund (MMF) shares/units (F.521))
Investmentfonds ohne Geldmarktfonds (F.522) (Non-MMF investment fund shares/units (F.522))

5.11 Code table fristigkeit

XML element: FRISTIGKEIT

Code list: Maturity

XML schema
taeglich (Daily)
bis 1 Monat (Up to 1 month)
ueber 1 Monat bis 3 Monate (More than 1 month and up to 3 months)
ueber 3 Monate bis 6 Monate (More than 3 months and up to 6 months)
ueber 6 Monate bis 1 Jahr (More than 6 months and up to 1 year)
ueber 1 Jahr bis 2 Jahre (More than 1 year and up to 2 years)
ueber 2 Jahre bis 3 Jahre (More than 2 years and up to 3 years)
ueber 3 Jahre bis 4 Jahre (More than 3 years and up to 4 years)
ueber 4 Jahre bis 5 Jahre (More than 4 years and up to 5 years)
ueber 5 Jahre bis 10 Jahre (More than 5 years and up to 10 years)
ueber 10 Jahre (More than 10 years)

5.12 Code table sektor

XML element: SEKTOR

Code list: Issuer sector according to ESA 2010

XML schema
nichtfinanzielle Kapitalgesellschaften (S.11) (Non-financial corporations (S.11))
Zentralbank (S.121) (Central bank (S.121))
Kreditinstitute (S.122) (Deposit-taking corporations (S.122))
Geldmarktfonds (S.123) (Money market funds (MMFs) (S.123))
Investmentfonds (ohne Geldmarktfonds) (S.124) (Non-MMF investment funds (S.124))
sonstige Finanzinstitute (S.125) (Other financial intermediaries (S.125))
Kredit- und Versicherungshilfstätigkeiten (S.126) (Financial auxiliaries (S.126))
firmeneigene Finanzierungseinrichtungen und Kapitalgeber (S.127) (Captive financial institutions and money lenders (S.127))
Versicherungsgesellschaften (S.128) (Insurance corporations (S.128))
Altersvorsorgeeinrichtungen (S.129) (Pension funds (S.129))
Bund (S.1311) (Central government (S.1311))
Laender (S.1312) (State government (S.1312))
Gemeinden (S.1313) (Local government (S.1313))
Sozialversicherungen (S.1314) (Social security funds (S.1314))
private Haushalte (S.14) (Households (S.14))
private Organisationen ohne Erwerbszweck (S.15) (Non-profit institutions serving households (S.15))

5.13 Code table geogr_fokus

XML element: GEOGR_FOKUS

Code list: Geographical focus

XML schema
Deutschland (Germany)
Europa (Europäischer Wirtschaftsraum (EWR)) (Europe (European Economic Area (EEA)))
Europa (ohne EWR) (Europe (excluding EEA))
Nordamerika (North America)
Suedamerika (South America)
Asien (Asia)
Ozeanien (Oceania)

Naher Osten (Middle East)
Afrika (Africa)
Supranational / gemischt (Supranational/mixed)

5.14 Code table `renten_fokus`

XML element: RENTEN_FOKUS

Code list: Focus on bonds

XML schema
kein Rentenfokus (No focus on bonds)
Unternehmensanleihen (Corporate bonds)
Staatsanleihen (Government bonds)
gemischt (Mixed)

5.15 Code table `immo_fokus`

XML element: IMMO_FOKUS

Code list: Focus on real estate investments

XML schema
kein Immofokus (No focus on real estate)
Buero (Office)
Handel/Gastronomie (Retail/Restaurant)
Industrie (Industry)
Hotel (Hotel)
Wohnen (Housing)
Multi-Strategie (Multi-strategy)
sonstiges (Other)

5.16 Code table `esg_typ`

XML element: ESG_TYP

Code list: ESG type

XML schema
kein ESG Typ (No ESG type)
SFDR Artikel 8 konform (Compliant with Article 8 SFDR)

SFDR Artikel 9 konform (Compliant with Article 9 SDFR)
sonstige (Other)

5.17 Code table verm_pos

XML element: VERMOEGENSPOSITION

Code list: Asset items

XML schema
Grundstuecke bebaut (Developed land)
Beteiligungen an Immobiliengeschaeften (Participating interests in real estate companies)
Beteiligungen an OEPP-Projektgesellschaften (Participating interests in PPP project companies)
Beteiligungen an sonstigen Gesellschaften (Participating interests in other companies)
Container (Containers)
Energieanlagen (Energy plants)
Luftfahrzeuge (Aircraft)
sonstige nichtfinanzielle Vermoegensgegenstaende (Other non-financial assets)
Schiffe (Ships)
Grundstuecke un bebaut (Undeveloped land)

5.18 Code table krypto

XML element: KRYPTOWERT

Code list: Crypto-assets

XML schema
Bitcoin
Ethereum
Tether
BNB
Solana
Lido Staked Ether
USDC
XRP
Dogecoin
Toncoin

Cardano
Shiba Inu
Avalanche
Wrapped Bitcoin
Chainlink
sonstige (Other)