

Statistics on investment funds

Electronic Reporting System

XML format descriptions

Version: 9 February 2015

This English translation is provided by the Deutsche Bundesbank's Language Services Division and is for information purposes only. This translation is not official. The only authoritative text is the original German one as published on the Bundesbank's website.

Table of contents

1	Introduction	3
1.1	Versions	3
2	Submission method	4
2.1	BBk ExtraNet	4
2.2	XML	4
2.3	Validation	4
3	Reporting file	5
3.1	File name	5
3.2	File format	6
3.2.1	Notation	6
3.2.2	Character set	6
3.2.3	XML declaration	6
3.2.4	Name spaces	6
3.3	Element descriptions	7
3.4	Data types	8
3.4.1	Elements	8
3.4.2	Simple data types	9
3.4.3	Complex data types	10
3.4.4	Groups	15
4	InvV report	17
4.1	XML report structure	17
4.2	LIEFERUNG-INVV (DELIVERY-INVV)	18
4.2.1	Attributes	18
4.2.2	Sub-elements	18
4.3	MELDUNG (REPORTING)	21
4.3.1	The BBK_INSTITUTS_ID on the templates must be identical to the BBK_INSTITUTS_ID of the element MELDER (REPORTER).	21
4.3.2	Sub-elements	21
4.4	InvV forms	24
4.4.1	ALLGEMEIN_GESELLSCHAFT // GENERAL INFORMATION ON COMPANY (V10389)	24
4.4.2	ALLGEMEIN_INVV // GENERAL INFORMATION ON INVESTMENT FUNDS (V10390)	27
4.4.3	MONATLICH_INVV // MONTHLY INVESTMENT FUND REPORT (V10391)	38
4.4.4	BEREINIGUNGEN // ADJUSTMENTS (V10392)	46
5	Appendix	49
5.1	Code table organisationsform	49
5.2	Code table typ	49
5.3	Code table art_inhaber_offen	49
5.4	Code table art_mittel	50
5.5	Code table art_ertrag	50
5.6	Code table notierung	50
5.7	Code table index_abbildung	51
5.8	Code table nutzungsart	51
5.9	Code table wpArt	51
5.10	Code table fristigkeit	51
5.11	Code table sektor	52

If you have any questions, please contact us at

if-statistik@bundesbank.de

1 Introduction

In the electronic reporting system XMW, reports can be submitted to the Deutsche Bundesbank in XML format.

This document describes the XML format to be used for submitting reports for the statistics on investment funds to the Deutsche Bundesbank.

Technical documentation (XML schema files) and the examples given in this document are also available separately on the Deutsche Bundesbank's website at

http://www.bundesbank.de/Navigation/DE/Service/Meldewesen/Bankenstatistik/Formate_XML/formate_xml.html.

1.1 Versions

No	Date	File	Change
1	15 January 2014	bbk_xmw_invv_doku.pdf	Document created
2	3 November 2014	bbk_xmw_invv_doku.pdf BbkXmwInvv_2015.xsd	<p>InvV-Schema: new data type text150; name of company, name of investment fund, name of Group, and data type text40 changed in Data type text150</p> <p>A REPORT (MELDUNG) may contain the disclosure of general information on the company (V10389) no more than one time.</p> <p>Changes: DISCONTINUATION (SCHLIESSUNG) renamed WIND-DOWN (ABWICKLUNG).</p> <p>ORGANIZATION OTHER (ORGANISATION_SONSTIGE) renamed ORGANIZATION CLOSED OTHER (ORGANISATION_GESCHL_SONSTIGE).</p> <p>TYPE OF OWNER OPEN (ART_INHABER_OFFEN) or TYPE OF OWNER CLOSED (ART_INHABER_GESCHL) will be optional in the future.</p> <p>Addition of the sub-category real estate company for SUPERORDINATED FUND ("UEBERGEORDNET"). Elimination of the sub-items "income distribution" (ertragsausschüttung); complex data type for "income distribution" no longer applies.</p>
3	9 February 2015	bbk_xmw_invv_doku.pdf BbkXmwInvv_2015.xsd	<p>EXTRANET-ID to begin with „EXN“ followed by 5 letters or digits;</p> <p>WhiteSpace changed for some elements from collapse to preserve;</p> <p>data type text150 renamed in text150_NonEmptyString, element cannot be left empty.</p>

2 Submission method

The monthly report for the statistics on investment funds is submitted as an XML file via the Bundesbank's ExtraNet.

2.1 BBk ExtraNet

For information on ExtraNet and registration options, see

<http://www.bundesbank.de/extranet/extranet.php>.

2.2 XML

XML (= "eXtensible Markup Language") is the industry standard for defining documents with hierarchically structured content. It allows the definition of elements and attributes. Elements are basic modules and are composed recursively of data and other elements. An element consists of a start tag `<elementname>`, the element content and an end tag `</elementname>`. In the start tag, attributes can be added to the element using the following syntax: `attributname="attribut"`. Each XML document has a tree structure with a unique root element.

Example

```
<elementname attributname="attribut">
  <elementname_1>elementinhalt_1</elementname_1>
  <elementname_2>elementinhalt_2</elementname_2>
</elementname>
```

XML is case-sensitive, ie it distinguishes between upper and lower case.

XML files are pure text files. Their file extension is ".xml".

For more information on XML, see <http://www.w3.org/XML/>.

2.3 Validation

An XML schema describes the layout of elements, their form (numbers, text, ...) and their attributes. An XML file is termed "valid" if it conforms to your schema. An XML file can be validated using standard tools.

3 Reporting file

3.1 File name

The file name of the XML file to be submitted comprises the identification for the statistics on investment funds (= InvV), the reporting month, the 5-digit BBk institution ID and a serial number. It is

invv_yyyymm_instid_lfnr.xml

Parameter	Contents
invv	Abbreviation for the statistics on investment funds
<i>yyymm</i>	Reporting month with the year as four digits and month as two digits
<i>instid</i>	5-digit BBk institution ID of reporting company
<i>lfnr</i>	2-digit serial number begins again in each new reporting month with "01"

Example: **invv_201412_00123_01.xml**

Several XML files (with correct names) can be combined in one ZIP file. The resulting ZIP file is named according to the same principle as the XML file (without a serial number). The extension is ".zip".

Example: **invv_201412_00123.zip**

Correction reports are to be identified in the file name.

Example: **invv_201412_00123_01_korrektur.xml**
 invv_201412_00123_korrektur.zip

The file name for test files must begin with "TEST_", both in ZIP and XML files. It does not matter whether the text is in upper or lower case.

Example: **TEST_invv_201412_00123_01.xml**
 test_invv_201412_00123.zip

3.2 File format

Report files are coded in XML.

As an aid for creating the file, XML schemas are available for download from the Bundesbank's website at

http://www.bundesbank.de/Navigation/DE/Service/Meldewesen/Bankenstatistik/Formate_XML/formate_xml.html.

To ensure data integrity, we recommend validating the generated XML files using the schema definitions.

Name	Description
BbkXmwBasis.xsd	Basic schema for XML reports to the Bundesbank
BbkXmwInvv_2015.xsd	Schema for XML reports for statistics on investment funds

3.2.1 Notation

XML is case-sensitive. In the Bundesbank's XML reporting system, the names of elements are usually written in upper-case letters, and those of attributes in lower-case letters. If different elements are located at the same hierarchical level, the sequence of elements is generally the determining factor. The sequence of attributes is arbitrary.

3.2.2 Character set

The character set is Latin-1/West European (ISO-8859-1). This ensures, among other things, that umlauts are displayed correctly.

The ampersand ("&") is not permissible. However, if it is needed, for instance in the name of a bank, then it should be replaced with "&".

Example: "Mark & Meier Bank" → "Mark & Meier Bank"

The less-than sign ("<") is also not permissible. However, if it is needed, then it should be replaced with "<" (or written in full).

Example: "If reporting date < 01-01-2014, then..." → "If reporting date < 01-01-2014, then..."

3.2.3 XML declaration

Each XML report begins with the XML declaration

```
<?xml version="1.0" encoding="ISO-8859-1"?>
```

which must always appear in the first line.

3.2.4 Name spaces

To differentiate the Bundesbank's general XMW schema (BbkXmwBasis.xsd) from the specific InvV schema (BbkXmwInvv_2015.xsd), the following name spaces are used:

Name	Name space
BbkXmwBasis.xsd	http://www.bundesbank.de/xmw/2003-01-01
BbkXmwInvv_2015.xsd	http://www.bundesbank.de/statistik/invv/v1

In the examples, the InvV name space is used as the standard name space, ie the elements of this name space do not require any qualification. For the general XMW name space, the abbreviation bbk is used, ie all elements from this name space must be qualified with "bbk:".

3.3 Element descriptions

The following table describes the elements.

Name	Req (= required)	Value range / format	Comments
ELEMENT NAME	+ Element is required - Element can be omitted *	Indication or description of permissible element content	Comment about the element
Attribute	+ Attribute is required - Attribute can be omitted	Indication or description of permissible attribute content	Comment about the attribute

* **If an element is to be omitted, then it should be eliminated in its entirety and not just its contents.**

3.4 Data types

The XMW schema definitions use self-defined elements and data types. They are described below.

3.4.1 Elements

I General schema

bbk:ISIN

12-digit securities identification number in ISIN format

The ISIN consists of 12 alphanumeric characters (upper-case letters and/or numbers). The first two characters are always upper-case letters (country identification), while the remaining 10 characters are made up of upper-case letters and numbers.

II InvV schema

BBK_INSTITUTS_ID

BBk institution ID

The Bundesbank assigns an institution ID to the reporting company. It is a 5-digit alphanumeric ID and for those companies that are already registered, it comprises the previous KAG number with preceding zeros.

The Bundesbank also assigns the required institution ID for third parties that are contracted by a company to submit the reports.

The institution ID (BBK_INSTITUTS_ID) on the templates must be identical to the BBK_INSTITUTS_ID of the element MELDER (REPORTER).

BIC

Business identifier code

The business identifier code (BIC) consists of at least 8 and no more than 11 numbers or upper-case letters.

LEI

Legal entity identifier

The legal entity identifier (LEI) is based on the ISO standard 17442 and consists of 20 alphanumeric characters.

INTERNE_KNR

Internal ID number

The internal ID number of investment funds without an ISIN for which a report is to be submitted or of held securities without an ISIN consists of 12 alphanumeric characters (upper-case letters and/or numbers).

For closed investment funds, the internal ID number corresponds to the BBK_INSTITUTS_ID with the preceding zeros.

3.4.2 Simple data types

I General schema

bbk:alphanum

1 to 80 characters, alphanumeric

The alphanum data type is used for text content, eg for name fields. Data of this type may be up to **80 characters** in length, but may **not be blank**. Only upper-case letters may be used. All characters of the ISO 8859-1 character set are permitted ("&" is to be replaced with "&" and "<" with "<"). Multiple spaces, tabs and line breaks are reduced to a single space during editing.

bbk:email

Valid e-mail address

A valid e-mail address takes the form: "characterstring@characterstring.do" (do = 2 to 4-digit domain name). A personal or functional address can be entered.

bbk:isoLand

ISO country code

ISO 3166 assigns every country a code consisting of two upper-case letters, eg "DE" for Germany. One number and one upper-case letter is permissible for international organisations, eg "1Z" for the United Nations.

bbk:isoWaehrung

ISO currency code

ISO 4217 assigns every currency a code consisting of three upper-case letters, eg "EUR" for euro.

bbk:jaNein

"yes" or "no"

The entry "yes" or "no" must always be written in lower case.

bbk:telNr

Valid telephone number format

A valid telephone number consists of a sequence of digits. The area code is optional and can be denoted by "(" or "/", and the extension can be introduced with "-". Spaces can be used to structure the number.

II InvV schema

text40

Maximum of 40 characters of alphanumeric text.

text150_NonEmptyString

Maximum of 150 characters of alphanumeric text. Element cannot be left empty.

betrag12

12digit amount

betrag12 specifies a number or amount in thousands of euro without any decimal places and comprising up to 12 digits. The amount is to be stated either in full without spaces or right-justified with preceding zeros or spaces.

Negative amounts have a minus sign ("-") in front of the first number. The number of digits is **not increased** by this (no more than 11 digits and one "-").

Commas, full stops and other separators are not permissible.

Examples

123456789012
123435
000012345678
-12345678901

betragglz

20-digit amount as floating point number:

betragglz specifies a number comprising up to 20 digits. The position of the decimal comma is not fixed and may be omitted. If the amount has a decimal point, however, at least one number must be before and after it. The entire length of the number may not exceed 20 digits, including the point. The amount is to be provided either in full without spaces or right-justified with preceding zeros or spaces.

Negative amounts have a minus sign ("-") in front of the first number. This does **not increase** the number of digits (no more than 19 digits and one "-" or no more than 18 digits and one comma and one "-").

Points and other separators are not permitted.

Examples

123456,12323
0,1232636353
12377363
-6635
47,2009
7,85
-8726,13

date_nicht_vorhanden

Consists of xs:date and "not available".

3.4.3 Complex data types

I General schema

bbk:adresse

The bbk:adresse data type standardises the form of companies' address data. It is used in the bbk:ERSTELLER (CREATOR), bbk:ADRESSAT (ADDRESSEES), bbk:ABSENDER (SENDER), bbk:MELDER (REPORTER) elements and contains the following sub-elements.

Name	Req	Value range / format	Comments
BBK_INSTITUTS_ID	+	alphanumeric, 5 characters	Number to identify the company that submits the XML report
NAME	+	bbk:alphanum	Name of company
STRASSE or POSTFACH	-	bbk:alphanum	Street / PO Box
PLZ	-	alphanumeric, 1 to 20 characters	Postcode
ORT	-	bbk:alphanum	Town / City
LAND	-	bbk:isoLand	Country of domicile of company
KONTAKT	+	see below	Contact person or unit

KONTAKT (CONTACT PERSON/UNIT)

Name	Req	Value range / format	Comments
ANREDE	-	bbk:alphanum	Form of address
VORNAME	-	bbk:alphanum	First name of contact person
ZUNAME	+	bbk:alphanum	Last name of contact person or name of functional contact unit
ABTEILUNG	-	bbk:alphanum	Division
TELEFON	+	bbk:telnr	Telephone number (with extension)
FAX	-	bbk:telnr	Fax number
EMAIL	-	bbk:email	E-mail address
EXTRANET-ID	-	"EXN" followed by 5 letters or digits	User name in the Bundesbank's ExtraNet (if available)

Example: bbk:ABSENDER (SENDER)

```

<bbk:ABSENDER>
  <BBK_INSTITUTS_ID>00123</BBK_INSTITUTS_ID>
  <bbk:NAME>Beispiel-Gesellschaft</bbk:NAME>
  <bbk:STRASSE>ABC-Straße 1</bbk:STRASSE>
  <bbk:PLZ>12345</bbk:PLZ>
  <bbk:ORT>Beispiel-Ort</bbk:ORT>
  <bbk:LAND>DE</bbk:LAND>
  <bbk:KONTAKT>
    <bbk:ANREDE>Herr</bbk:ANREDE>
    <bbk:VORNAME>Hans</bbk:VORNAME>
    <bbk:ZUNAME>Schmidt</bbk:ZUNAME>
    <bbk:ABTEILUNG>Investmentvermoeegen</bbk:ABTEILUNG>
    <bbk:TELEFON>000/111-999</bbk:TELEFON>
    <bbk:FAX>000/111-888</bbk:FAX>
    <bbk:EMAIL>hans.schmidt@gesellschaft.de</bbk:EMAIL>
    <bbk:EXTRANET-ID>EXNTESTA</bbk:EXTRANET-ID>
  </bbk:KONTAKT>
</bbk:ABSENDER>
    
```

It is essential to enter the optional elements in bbk:MELDER (REPORTER), bbk:ABSENDER (SENDER) and bbk:ERSTELLER (CREATOR) to ensure smooth processing within the Bundesbank.

II InvV schema (V10390)

gesellschaftsinNameLand

Company information: ID, name, country

Name	Req	Value range / format	Comments
(InvV-Kennung)	+	invv_kennung	ID of investment fund (ISIN or internal ID)
NAME	+	text150_NonEmptyString	Name of company
LAND	+	bbk:isoLand	Country of domicile of company

gesellschaftNameLand

Company information: name, country

Name	Req	Value range / format	Comments
NAME	+	text150_NonEmptyString	Name of company

LAND	+	bbk:isoLand	Country of domicile of company
------	---	-------------	--------------------------------

III InvV schema (V10391)

wpMitISIN

Information on V10391, item 11 (can be repeated as often as required)

Name	Req	Value range / format	Comments
ISIN	+	bbk:ISIN	ISIN of security
<i>(Kurs-/Stück- angaben)</i>	+	wpKursStueck	Price or number of units and currency of a security
DARUNTER_WP_LEIHG	+	betragglz	<i>of which</i> securities lending transactions (nominal value in euro or number of units)
DARUNTER_ECHTE_PG	+	betragglz	<i>of which</i> real repo transactions (nominal value in euro or number of units)

wpOhneISIN

Information on V10391, item 12 (can be repeated as often as required)

Name	Req	Value range / format	Comments
INTERNE_KNR	+	INTERNE_KNR	Internal ID of security
WERTPAPIERART	+	Code table wpArt	Type of security
EMITTENTENLAND	+	bbk:isoLand	Country of domicile of issuer
EMITTENTENSEKTOR	+	Code table sektor	Sector of issuer
EMISSIONSDATUM	+	xs:date	Issue date (YYYY-MM-DD)
FAELLIGKEITSDATUM	+	date_nicht_vorhanden	Maturity date (YYYY-MM-DD) or "not available" if information for securities that are not dated is not available
<i>(Kurs-/Stück- angaben)</i>	+	wpKursStueck	Price or number of units and currency of a security
DARUNTER_WP_LEIHG	+	betragglz	<i>of which</i> securities lending transactions (nominal value in euro or number of units)
DARUNTER_ECHTE_PG	+	betragglz	<i>of which</i> real repo transactions (nominal value in euro or number of units)

bankguthaben (bank deposits)

Information on V10391, item 20

Name	Req	Value range / format	Comments
GESAMTBETRAG	+	betrag12	Total amount in thousands of euro
ANGABEN	+	see below	Specific information on item 20

ANGABEN (INFORMATION) (can be repeated as often as required)

BETRAG	+	betrag12	Amount in thousands of euro
WAEHRUNG	+	bbk:isoWaehrung	Currency
LAND	+	bbk:isoLand	Country of domicile of institution
SEKTOR	+	Code table sektor	Sector of institution
FRISTIGKEIT	+	Code table fristigkeit	Maturity of bank deposits

forderungen (claims)

Information on V10391, items 31-35

Name	Req	Value range / format	Comments
GESAMTBETRAG	+	betrag12	Total amount in thousands of euro
ANGABEN	+	see below	Specific information on items 31, 32, 33, 34 and 35

ANGABEN (INFORMATION) (can be repeated as often as required)

BETRAG	+	betrag12	Amount in thousands of euro
WAEHRUNG	+	bbk:isoWaehrung	Currency
LAND	+	bbk:isoLand	Country of domicile of debtor
SEKTOR	+	Code table sektor	Sector of debtor
FRISTIGKEIT	+	Code table fristigkeit	Maturity of claims
VERBUNDE- NES_UNTERNEHMEN	+	bbk:jaNein	Is debtor an affiliated company?

nf_vermoegen (n-f assets)

Information on V10391, items 51-57 (excl 52)

Name	Req	Value range / format	Comments
GESAMTBETRAG	+	betrag12	Total amount in thousands of euro
ANGABEN	+	see below	Specific information on items 51, 53, 54, 55, 56 and 57

ANGABEN (INFORMATION) (can be repeated as often as required)

BETRAG	+	betrag12	Amount in thousands of euro
LAND	+	bbk:isoLand	Country in which asset is located or manufacturing country for movable assets
ANZAHL	+	betrag12	Number of assets

nf_vermoegen_grundst_beb (n-f assets: developed land)

Information on V10391, item 52

Name	Req	Value range / format	Comments
GESAMTBETRAG	+	betrag12	Total amount in thousands of euro
ANGABEN	+	see below	Specific information on item 52

ANGABEN (INFORMATION) (can be repeated as often as required)

BETRAG	+	betrag12	Amount in thousands of euro
LAND	+	bbk:isoLand	Country in which property is located
ANZAHL	+	betrag12	Number of properties
NUTZUNGSART	+	Code table nutzungsart	Type of use of property

beteiligungen (participating interests)

Information on V10391, items 61-63

Name	Req	Value range / format	Comments
GESAMTBETRAG	+	betrag12	Total amount in thousands of euro
ANGABEN	+	see below	Specific information on items 61, 62 and 63

ANGABEN (INFORMATION) (can be repeated as often as required)

BETRAG	+	betrag12	Amount in thousands of euro
LAND	+	bbk:isoLand	Country of domicile of company

sonst_vermoegen (other assets)

Information on V10391, items 70-73

Name	Req	Value range / format	Comments
GESAMTBETRAG	+	betrag12	Total amount in thousands of euro (item 70)
ZINSEN_EINLAGEN	-	betrag12	<i>of which</i> accrued interest on deposits (in thousands of euro) (item 71)
ZINSEN_WERTPAPIERE	-	betrag12	<i>of which</i> accrued interest from securities other than shares (in thousands of euro) (item 72)
FORDERUNGEN	-	betrag12	<i>of which</i> claims from dividends (in thousands of euro) (item 73)

verbindlichkeiten (liabilities)

Information on V10391, items 81-82

Name	Req	Value range / format	Comments
GESAMTBETRAG	+	betrag12	Total amount in thousands of euro
ANGABEN	+	see below	Specific information on items 81 and 82

ANGABEN (INFORMATION) (can be repeated as often as required)

BETRAG	+	betrag12	Amount in thousands of euro
WAEHRUNG	+	bbk:isoWaehrung	Currency
LAND	+	bbk:isoLand	Country of domicile of creditor
SEKTOR	+	Code table sektor	Sector of creditor
FRISTIGKEIT	+	Code table fristigkeit	Maturity of liabilities
MINDESTRESER- VEPFL_INST	-	bbk:jaNein	Is creditor subject to minimum reserve requirements? (only mandatory for money market funds)

sonst_verbindlichkeiten (other liabilities)

Information on V10391, items 100-101

Name	Req	Value range / format	Comments
GESAMTBETRAG	+	betrag12	Total amount in thousands of euro (item 100)
ZINSEN_AUFGELAUFEN	-	betrag12	<i>of which</i> accrued interest (in thousands of euro) (item 101)

mittelabfluesse (outflows)

Information on V10391, items 206-207

Name	Req	Value range / format	Comments
GESAMTBETRAG	+	betrag12	Total amount in thousands of euro (item 206)
SUBSTANZ_KAPITAL	-	betrag12	of which capital payment / repayment (in thousands of euro) (item 207)

IV InvV schema (V10392)

angaben_ber (adjustment info)

Information on V10392, items B51-B63

Name	Req	Value range / format	Comments
GESAMTBETRAG	+	betrag12	Total amount in thousands of euro
ANGABEN	+	see below	Specific information on items B51, B52, B53, B54, B55, B56, B57, B61, B62 and B63

ANGABEN (INFORMATION) (can be repeated as often as required)

BETRAG	+	betrag12	Amount in thousands of euro
LAND	+	bbk:isoLand	Country in which asset is located or manufacturing country for movable assets

3.4.4 Groups

I InvV schema

formular_kopf

Form header for monthly reports (V10391 and V10392)

Name	Req		Comments
BBK_INSTITUTS_ID	+	BBK_INSTITUTS_ID	BBK institution ID
INVV_NAME	+	text150_NonEmptyString	Name of investment fund
(InvV-Kennung)	+	invv_kennung	ID of investment fund (ISIN or internal ID)

invv_kennung

ID of investment fund: ISIN information. If no ISIN is available, an internal ID must be provided.

Name	Req	Value range / format	Comments
ISIN or INTERNE_KNR	+	bbk:ISIN INTERNE_KNR	ISIN or internal ID of investment fund

wpKursStueck

Price or number of units and currency of a security

Name	Req	Value range / format	Comments
NOMINALWERT	+	betragglz	Securities quoted as a percentage:

KURS	+	betragglz	Nominal value in euro and price as a percentage (at least 3 decimal places)
------	---	-----------	---

or

STUECKZAHL	+	betragglz	Securities quoted as a number of units: Number of units and price per unit in euro (at least 2 decimal places)
PREIS	+	betragglz	

WAEHRUNG	+	bbk:isoWaehrung	Currency
----------	---	-----------------	----------

wpKursPreis

Price of an investment fund

Name	Req	Value range / format	Comments
KURS	+	betragglz	Securities quoted as a percentage: Price as a percentage (at least 3 decimal places)

or

PREIS	+	betragglz	Securities quoted as a number of units: Price per unit in euro (at least 2 decimal places)
-------	---	-----------	---

wpNwStueck

Nominal value or number of units of a security

Name	Req	Value range / format	Comments
NOMINALWERT	+	betrag12	Securities quoted as a percentage: Nominal value in thousands of euro

or

STUECKZAHL	+	betrag12	Securities quoted as a number of units: Number in euros
------------	---	----------	--

4 InvV report

4.1 XML report structure

All XML banking statistics files have a common, basic hierarchical structure. It begins with a root element with address information (LIEFERUNG-INVV (DELIVERY)). It contains a reporting element (MELDUNG (REPORTING)) which, in turn, contains form elements. The form elements (InvV forms) contain reporting data at the lowest level of detail.

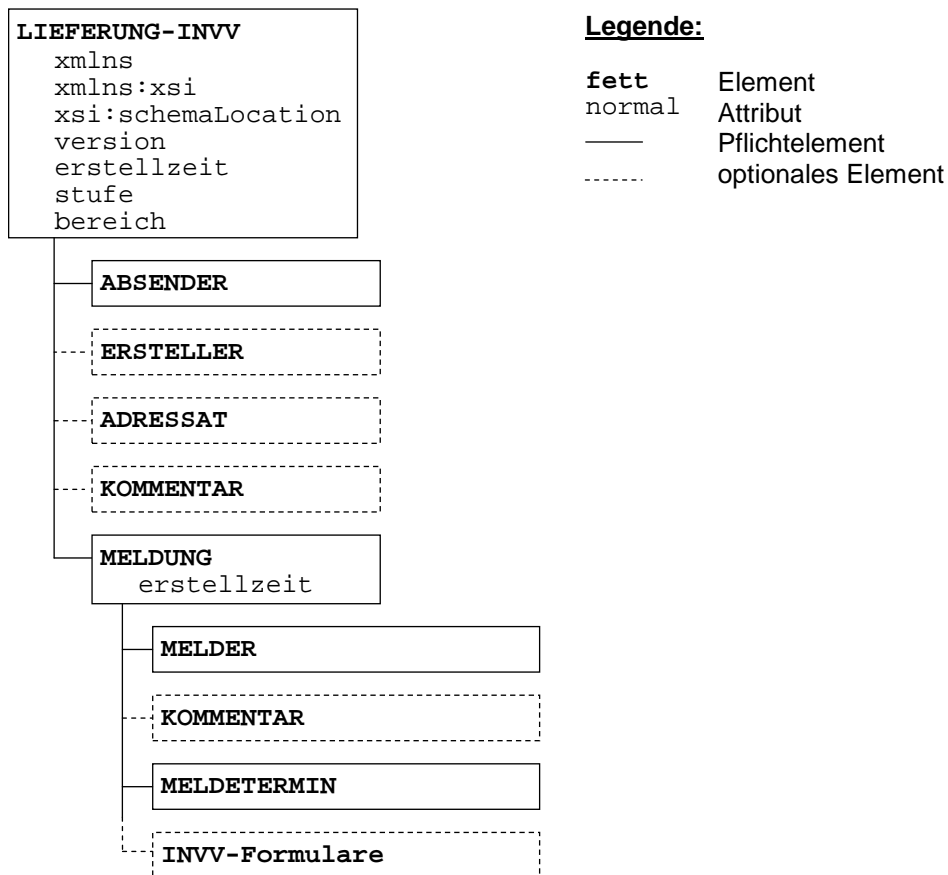

Figure 4-1

4.2 LIEFERUNG-INNV (DELIVERY-INNV)

The root element of an INNV-XMW report is called `LIEFERUNG-INNV`.

4.2.1 Attributes

Name	Req	Value range / format	Comments
<code>xmlns</code>	+	<code>http://www.bundesbank.de/statistik/invv/v1</code>	Name space of XML reporting for statistics on investment funds, version 1
<code>xmlns:innv</code>	-	<code>http://www.bundesbank.de/statistik/invv/v1</code>	Name space of XML reporting for statistics on investment funds, version 1
<code>xmlns:bbk</code>	+	<code>http://www.bundesbank.de/xmw/2003-01-01</code>	Name space for XML reporting
<code>xmlns:xsi</code>	+	<code>http://www.w3.org/2001/XMLSchema-instance</code>	Name space for XML schema definition
<code>xsi:schemaLocation</code>	+	<code>http://www.bundesbank.de/statistik/invv/v1/BbkXmwInnv_2015.xsd</code>	Search path for XML schema
<code>version</code>	+	"1.0"	Currently fixed
<code>erstellzeit</code>	+	yyyy-mm-ddThh:mm:ss	Example: 2015-01-03T12:00:00
<code>stufe</code>	+	"Test" or "production"	Distinguishes between test and production data
<code>bereich</code>	+	"Statistics"	
<code>dateireferenz</code>	-	Whole number ("1", "2", ...)	Counter for repeated submissions

4.2.2 Sub-elements

Name	Req	Value range / format	Comments
<code>bbk:ABSENDER</code>	+	<code>bbk:adresse</code>	Address of sender
<code>bbk:ERSTELLER</code>	-	<code>bbk:adresse</code>	Address of creator
<code>bbk:ADRESSAT</code>	-	<code>bbk:adresse</code>	Address of addressees
<code>bbk:KOMMENTAR</code>	-	<code>bbk:alphanum</code>	Comments on report
<code>MELDUNG</code>	+	See 4.3 MELDUNG (REPORTING)	INNV reporting data

The `bbk:ABSENDER` element is of the `bbk:adresse` data type. The contents include address information on the company that submitted the XML file. The first sub-element is `BBK_INSTITUTS_ID`; this is where the institution ID that the Bundesbank assigned to the reporting company should be entered.

The `bbk:ERSTELLER` element is optional and of the `bbk:adresse` data type. It contains address information on the party creating the XML report if s/he is not identical to the sender.

The `bbk:ADRESSAT` element is optional and of the `bbk:adresse` data type. As a general rule, it is not used for reports submitted to the Deutsche Bundesbank; it is intended for use when exchanging data with third parties.

The optional `bbk:KOMMENTAR` element is irrelevant for statistics on investment funds.

The `MELDUNG` element is mandatory and may appear several times. It contains the report forms for statistics on investment funds.

Structure: LIEFERUNG-INVV // DELIVERY-INVV

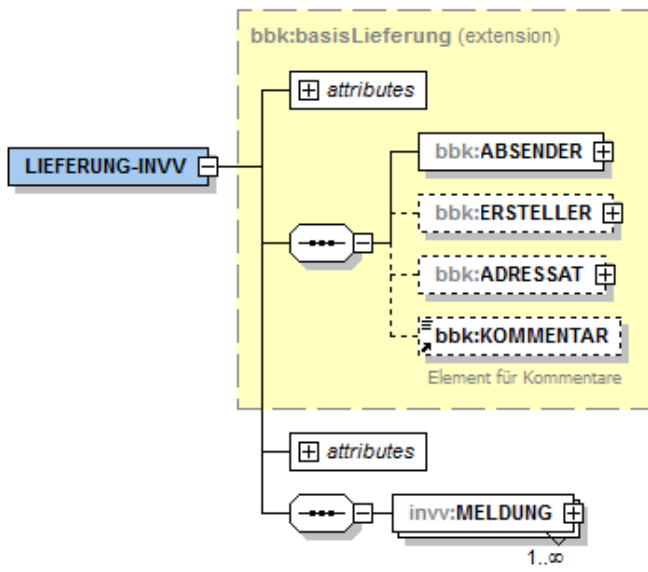

Figure 4-2

Example: LIEFERUNG-INVV // DELIVERY-INVV

```
<?xml version="1.0" encoding="ISO-8859-1"?>
<LIEFERUNG-INVV
  xmlns="http://www.bundesbank.de/statistik/invv/v1"
  xmlns:invv="http://www.bundesbank.de/statistik/invv/v1"
  xmlns:bbk="http://www.bundesbank.de/xmw/2003-01-01"
  xmlns:xsi="http://www.w3.org/2001/XMLSchema-instance"
  xsi:schemaLocation="http://www.bundesbank.de/statistik/invv/v1 BbkXmwInvv_2015.xsd"
  version="1.0"
  erstellzeit="2015-01-03T12:00:00"
  dateireferenz="0"
  stufe="Test"
  bereich="Statistik">
  <bbk:ABSENDER>
    <BBK_INSTITUTS_ID>00123</BBK_INSTITUTS_ID>
    <bbk:NAME>Beispiel-Gesellschaft</bbk:NAME>
    <bbk:STRASSE>ABC-Straße 1</bbk:STRASSE>
    <bbk:PLZ>12345</bbk:PLZ>
    <bbk:ORT>Beispiel-Ort</bbk:ORT>
    <bbk:LAND>DE</bbk:LAND>
    <bbk:KONTAKT>
      <bbk:ZUNAME>Schmidt</bbk:ZUNAME>
      <bbk:ABTEILUNG>Investmentvermoegen</bbk:ABTEILUNG>
      <bbk:TELEFON>000/111-999</bbk:TELEFON>
      <bbk:FAX>000/111-888</bbk:FAX>
      <bbk:EMAIL>hans.schmidt@gesellschaft.de</bbk:EMAIL>
      <bbk:EXTRANET-ID>EXNTESTA</bbk:EXTRANET-ID>
    </bbk:KONTAKT>
  </bbk:ABSENDER>
  <bbk:ERSTELLER>
    <BBK_INSTITUTS_ID>00123</BBK_INSTITUTS_ID>
    <bbk:NAME>Beispiel-Gesellschaft</bbk:NAME>
    <bbk:KONTAKT>
      <bbk:ZUNAME>Otto</bbk:ZUNAME>
      <bbk:TELEFON>000/111-777</bbk:TELEFON>
    </bbk:KONTAKT>
  </bbk:ERSTELLER>
  <bbk:KOMMENTAR>Dies ist eine Testlieferung</bbk:KOMMENTAR>
  <MELDUNG erstellzeit="2015-01-03T12:00:00">
    <!-- ***** Meldung für die Statistik über Investmentvermögen ***** -->
  </MELDUNG>
</LIEFERUNG-INVV>
```

4.3 MELDUNG (REPORTING)

The reporting element of an INVV XMW report is called MELDUNG.

4.3.1 The BBK_INSTITUTS_ID on the templates must be identical to the BBK_INSTITUTS_ID of the element MELDER (REPORTER).

Name	Req *	Value range / format	Comments
erstellzeit	+	yyyy-mm-ddThh:mm:ss	Example: 2015-01-03T12:00:00

* Where optional elements are blank, they can be omitted.

4.3.2 Sub-elements

Name	Req	Value range / format	Comments
bbk:MELDER	+	bbk:adresse	Master data of reporting party
bbk:KOMMENTAR	-	bbk:alphanum	Comments on report
bbk:MELDETERMIN	+	xs:gYearMonth	Reporting month (YYYY-MM)
ALLGEMEIN_GESELLSCHAFT	-	See 4.4.1 ALLGEMEIN_GESELLSCHAFT // GENERAL INFORMATION ON COMPANY (V10389)	General information on reporting company (V10389)
ALLGEMEIN_INVV	-	See 4.4.2 ALLGEMEIN_INVV // GEN- ERAL INFORMATION ON INVESTMENT FUNDS (V10390)	General information on individual investment fund (V10390)
MONATLICH_INVV	-	See 4.4.3 MONATLICH_INVV // MONTH- LY INVESTMENT FUND RE- PORT (V10391)	Monthly investment fund report (V10391)
BEREINIGUNGEN	-	See 4.4.4 BEREINIGUNGEN // AD- JUSTMENTS (V10392)	Monthly investment fund report (excl money market funds) – adjustments due to revaluation (V10392)

In the MELDUNG element, you may include as many forms as required.

Structure: MELDUNG // REPORTING

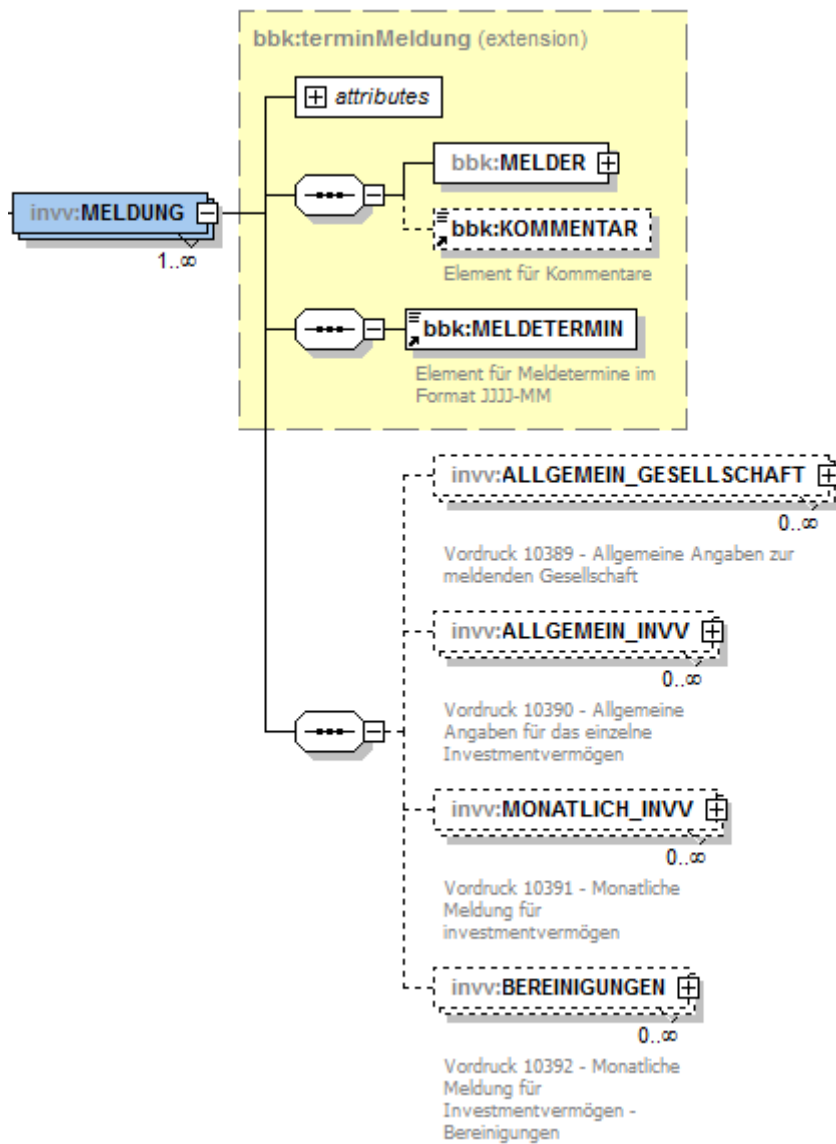

Figure 4-3

Example: MELDUNG // REPORTING

```
<MELDUNG erstellzeit="2015-01-03T12:00:00">
  <!-- ***** Meldung für die Statistik über Investmentvermögen ***** -->
  <bbk:MELDER>
    <BBK_INSTITUTS_ID>00123</BBK_INSTITUTS_ID>
    <bbk:NAME>Beispiel-Gesellschaft</bbk:NAME>
    <bbk:STRASSE>ABC-Straße 1</bbk:STRASSE>
    <bbk:PLZ>12345</bbk:PLZ>
    <bbk:ORT>Beispiel-Ort</bbk:ORT>

    <bbk:KONTAKT>
      <bbk:ZUNAME>Otto</bbk:ZUNAME>
      <bbk:TELEFON>000/111-777</bbk:TELEFON>
    </bbk:KONTAKT>

  </bbk:MELDER>
  <bbk:KOMMENTAR>Dies ist eine Testmeldung</bbk:KOMMENTAR>
  <bbk:MELDETERMIN>2014-12</bbk:MELDETERMIN>

  <ALLGEMEIN_GESELLSCHAFT>
    <!-- InvV-Formular V10389 -->
  </ALLGEMEIN_GESELLSCHAFT>
</MELDUNG>
```

4.4 InvV forms

4.4.1 ALLGEMEIN_GESELLSCHAFT // GENERAL INFORMATION ON COMPANY (V10389)

The report for the general information on the company is to be transferred immediately after the company is formed.

In the first reporting month (December 2014), the report is to be submitted once for all the companies required to file reports.

If there is a change in one or more features, the entire report is to be immediately resubmitted. The reporting of the general information about the company may only be made once per REPORT element.

Name	Req	Value range / format	Comments
GESELLSCHAFT	+	see below	Information on company
KONZERN	-	see below	Information on Group

GESELLSCHAFT (COMPANY)

BBK_INSTITUTS_ID	+	BBK_INSTITUTS_ID	5-digit BBk institution ID; former KAG number, right-justified with preceding zeros
BAFIN_ID	-	bbk:alphanum 8 digit	BaFin ID of company; 8 alphanumeric characters
LEI	-	LEI	Legal entity identifier; 20 alphanumeric characters
NAME	+	text150_NonEmptyString	Name of company
ANSCHRIFT	+	see below	Address of company
LAND	+	bbk:isoLand	Country of domicile of company
KONTAKTPERSON	+	see below	Contact person for statistics on investment funds

KONZERN (GROUP) (information required if there is a corporate group)

NAME	+	text150_NonEmptyString	Name of Group
LEI	-	LEI	Legal entity identifier; 20 alphanumeric characters
BIC	-	BIC	Business identifier code; 8 to 11 digits, numbers or upper-case letters
LAND	+	bbk:isoLand	Country of domicile of Group

ANSCHRIFT (ADDRESS)

STRASSE	+	bbk:alphanum	Street
PLZ	+	5-digit, numeric	Postcode
ORT	+	bbk:alphanum	Town / City

KONTAKTPERSON (CONTACT PERSON)

ANREDE	+	"Mr", "Ms"	Form of address
VORNAME	-	bbk:alphanum	First name of contact person
ZUNAME	+	bbk:alphanum	Last name of contact person
ABTEILUNG	-	bbk:alphanum	Division
TELEFON	+	bbk:telnr	Telephone number
FAX	-	bbk:telnr	Fax number
EMAIL	+	bbk:email	E-mail address
EXTRANET_ID	+	bbk:alphanum	ExtraNet ID

Structure: ALLGEMEIN_GESELLSCHAFT // GENERAL INFORMATION ON COMPANY (V10389)

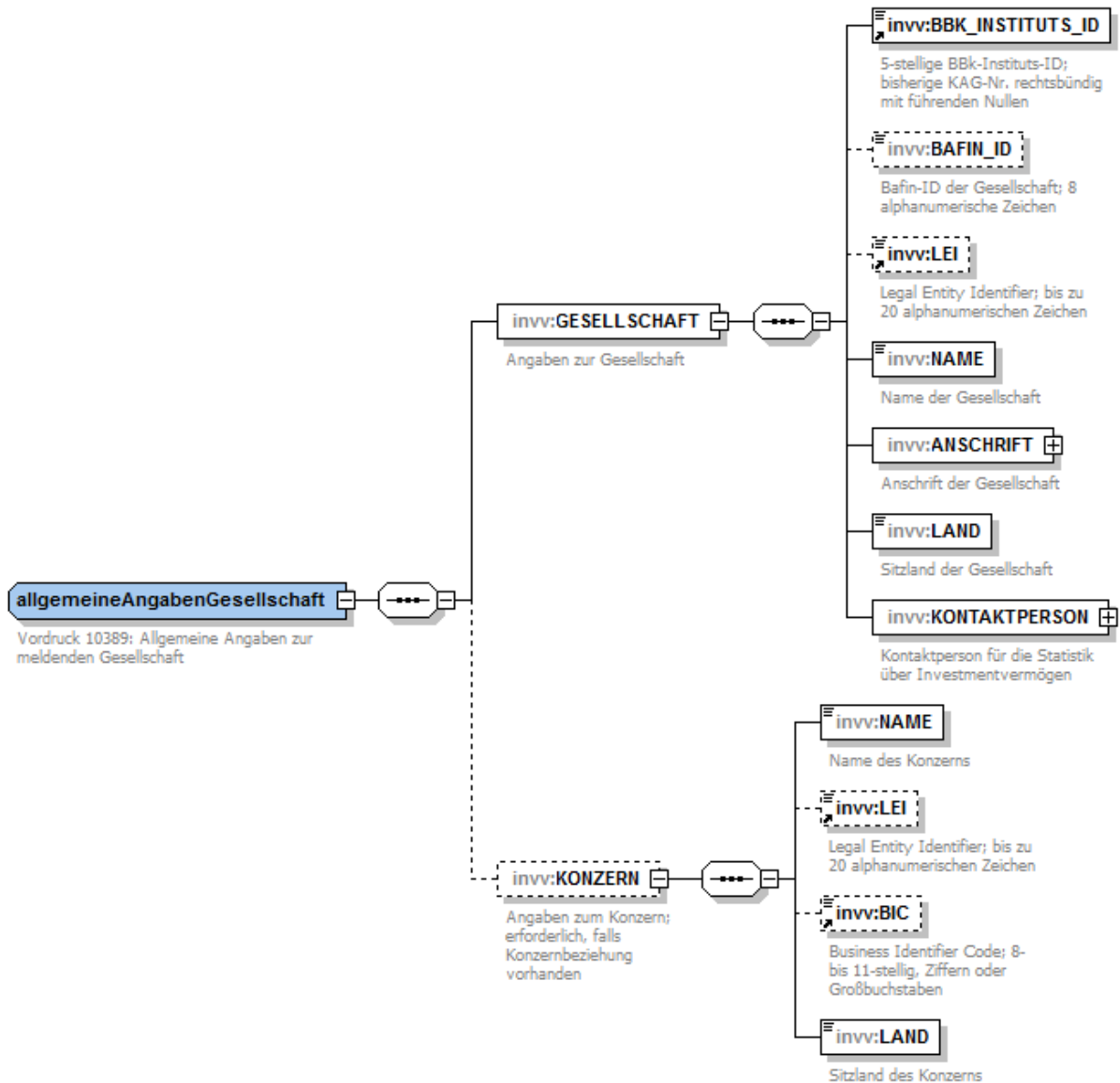

Figure 4-4

Example: ALLGEMEIN_GESELLSCHAFT // GENERAL INFORMATION ON COMPANY (V10389)

```
<ALLGEMEIN_GESELLSCHAFT>
  <GESELLSCHAFT>
    <BBK_INSTITUTS_ID>00123</BBK_INSTITUTS_ID>
    <BAFIN_ID>12345678</BAFIN_ID>
    <LEI>123400A1B2C3D4E5F699</LEI>
    <NAME>Beispiel-Gesellschaft</NAME>
    <ANSCHRIFT>
      <STRASSE>ABC-Straße 1</STRASSE>
      <PLZ>12345</PLZ>
      <ORT>Beispiel-Ort</ORT>
    </ANSCHRIFT>
    <LAND>DE</LAND>
    <KONTAKTPERSON>
      <ANREDE>Herr</ANREDE>
      <VORNAME>Hans</VORNAME>
      <ZUNAME>Schmidt</ZUNAME>
      <ABTEILUNG>Investmentvermoegen</ABTEILUNG>
      <TELEFON>000/111-999</TELEFON>
      <FAX>000/111-888</FAX>
      <EMAIL>hans.schmidt@gesellschaft.de</EMAIL>
      <EXTRANET_ID>EXNTESTA</EXTRANET_ID>
    </KONTAKTPERSON>
  </GESELLSCHAFT>
  <KONZERN>
    <NAME>Beispiel-Konzern</NAME>
    <LEI>123400A1B2C3D4E5F699</LEI>
    <BIC>A1B2C3D4E5F</BIC>
    <LAND>DE</LAND>
  </KONZERN>
</ALLGEMEIN_GESELLSCHAFT>
```

4.4.2 ALLGEMEIN_INVV // GENERAL INFORMATION ON INVESTMENT FUNDS (V10390)

The report is submitted immediately if new issues are offered for an investment fund, asset classes or sub-investment funds are created or if there is a take-over/closure, transfer or merger of investment funds.

In the first reporting month (December 2014), the report is to be submitted once for all the existing investment funds.

If there is a change in one or more features, the entire report is to be immediately resubmitted.

Name	Req	Value range / format	Comments
(Formular-Kopf)	+	formular_kopf	BBk institution ID, name and ID of investment fund
RECHT	+	bbk:isoLand	Applicable law (country): Country whose law investment fund is subject to
LEI	-	LEI	Legal entity identifier; 20 alphanumeric characters

ERSTMELDUNG	+	see below	Initial report
-------------	---	-----------	----------------

or

AENDERUNGSMELDUNG	+	see below	Change report
-------------------	---	-----------	---------------

ORGANISATION	+	Code table organi- sationsform	Form of organisation of investment fund (excl other)
--------------	---	-----------------------------------	--

or

ORGANISATI- ON_GESCHL_SONSTIG E	+	text40	Form of organisation of closed investment fund: other; here: enter text
---------------------------------------	---	--------	---

TYP	+	Code table typ	Type of investment fund
-----	---	----------------	-------------------------

ART_INHABER_OFFEN	-	Code table art_inhaber_offen	Type of unit holder with open-ended investment funds
-------------------	---	---------------------------------	--

or

ART_INHABER_GESCHL	-	see below	Type of unit holder with closed-ended investment funds (in thousands of euro) (can be repeated as often as required)
--------------------	---	-----------	--

ART_MITTELANLAGE	+	Code table art_mittel	Type of investment fund according to investment activity (no fund of fund)
------------------	---	--------------------------	--

or

ART_MITTELANLAGE_ DACHFONDS	+	Code table art_mittel	Type of investment fund according to investment activity: fund of fund; here: investment focus
--------------------------------	---	--------------------------	--

ART_ERTRAG	+	Code table art_ertrag	Type of investment fund according to income use
ART_LAUFZEIT	+	see below	Type of investment fund according to maturity
ART_RUECKNAHME	+	see below	Type of redemption certificate
NOTIERUNG	+	Code table notierung	Quotation type for fund units
INDEX	+	see below	Index fund

WERTGESICHERT	+	bbk: jaNein	Is the fund guaranteed?
MASTER	-	invv_kennung	ID of related feeder if report is for master (can be repeated as often as required)
or			
FEEDER	-	invv_kennung	ID of related master, if report is for feeder (to be entered once only)
UEBERGEORDNET	-	see below	ID of superordinated fund (if applicable)

Structure: ALLGEMEIN_INVV // GENERAL INFORMATION ON INVESTMENT FUNDS (V10390)

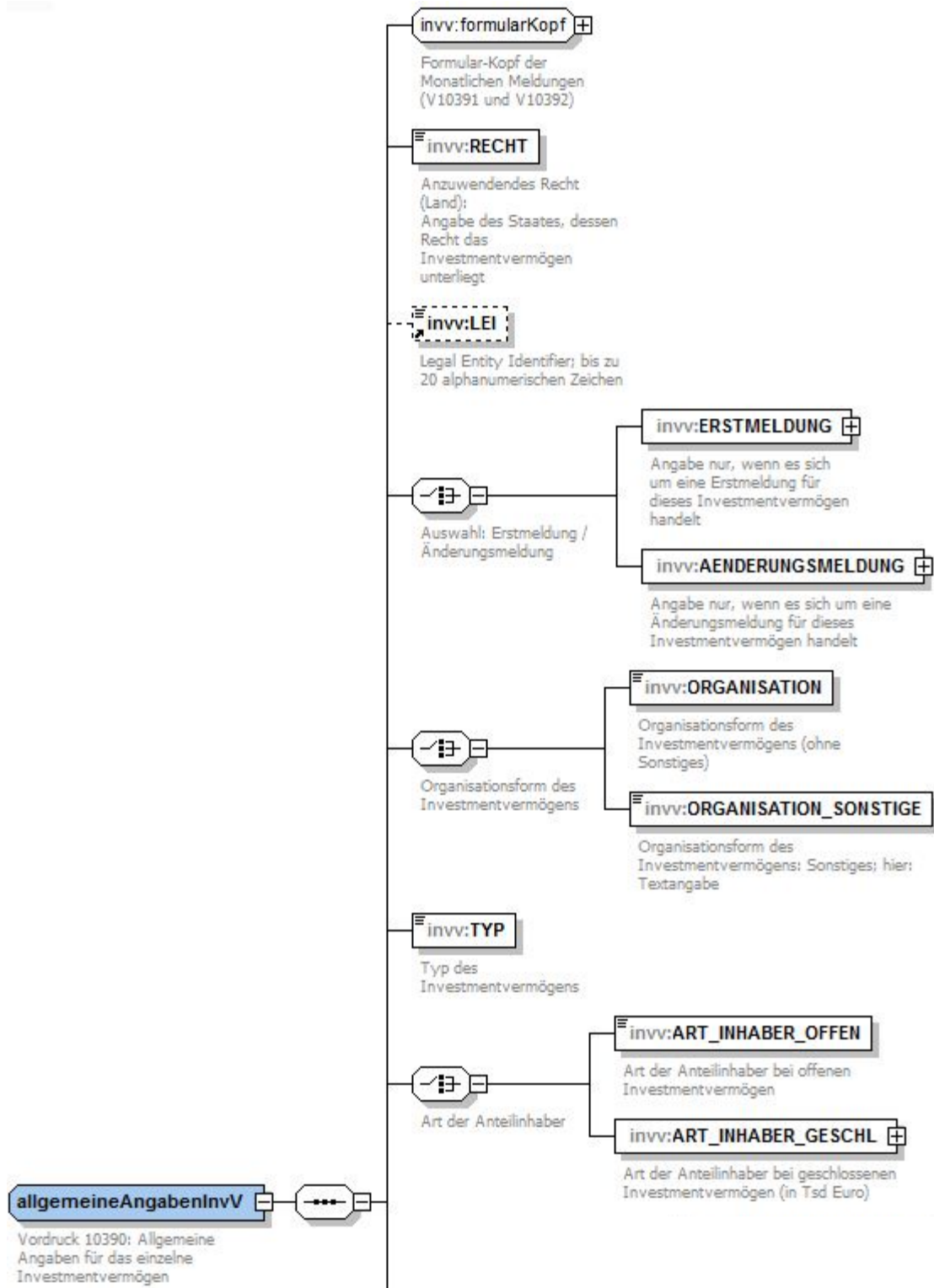

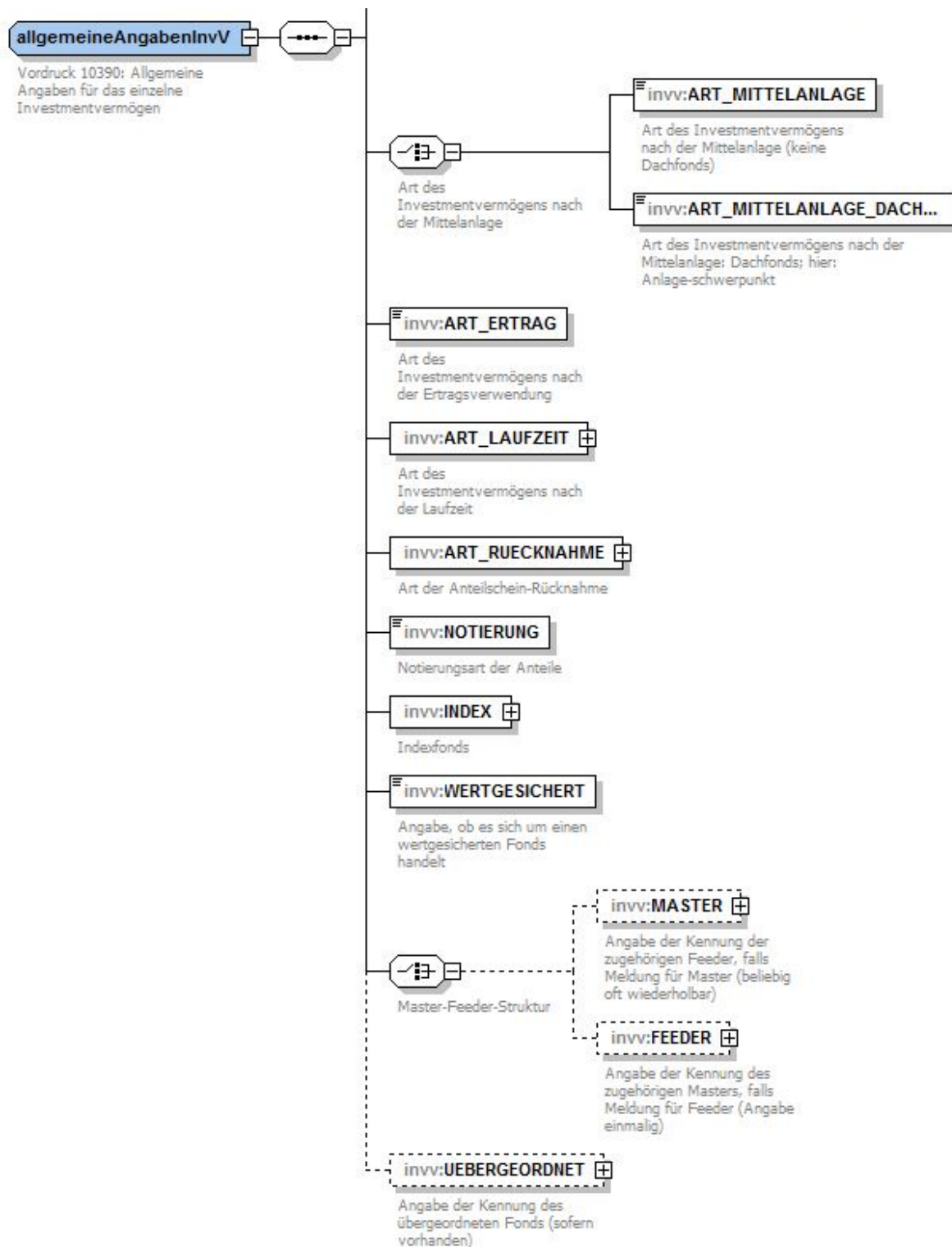

Figure 4-5

ERSTMELDUNG (INITIAL REPORT)

Information on V10390, item 06

DATUM	+	xs:date	Launch date (YYYY-MM-DD)
GRUND	+	see below	Only one entry: NEUAUFLAGE or UEBERNAHME

NEUAUFLAGE	+	blank: <NEUAUFLA- GE/>	Create blank entry for a new issue
------------	---	---------------------------	------------------------------------

or

UEBERNAHME	+	gesellschaftI- sinNameLand	ISIN or internal ID of investment fund before take-over as well as name and country of domicile of company that originally issued investment fund
------------	---	-------------------------------	--

Structure: ERSTMELDUNG // INITIAL REPORT

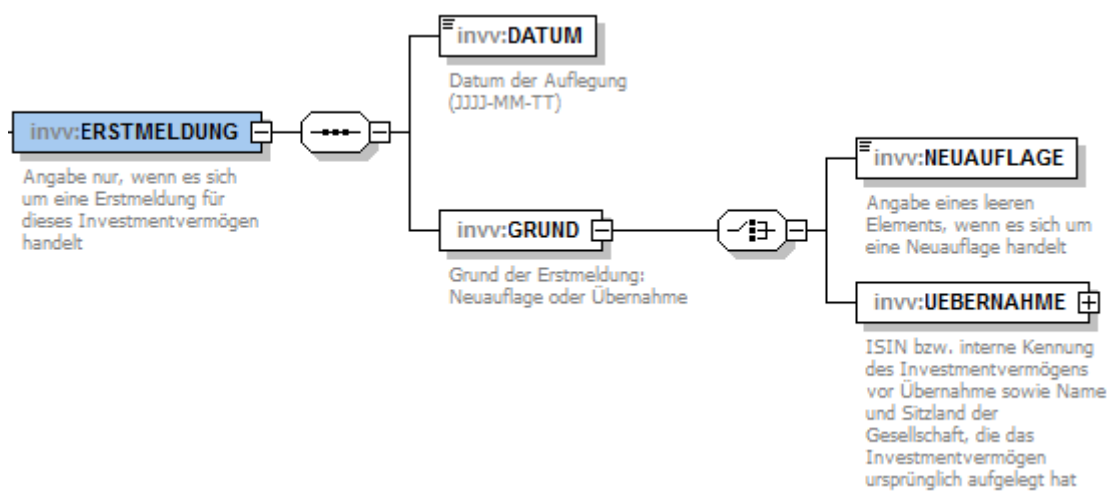

Figure 4-6

AENDERUNGSMELDUNG (CHANGE REPORT)

Information on V10390, item 07

DATUM	+	xs:date	Date of change (YYYY-MM-DD)
GRUND	+	see below	Only one entry: SCHLIESSUNG or ÜBERTRAGUNG or VER- SCHMELZUNG or SONSTIGES

ABWICKLUNG	+	blank: <ABWICKLUNG/>	Create blank entry for investment fund being wound down
------------	---	----------------------	---

or

UEBERTRAGUNG	+	gesellschaftNameLand	Name and country of domicile of company receiving transfer
--------------	---	----------------------	--

or (can be repeated as often as required for a merger with several investment funds)

VERSCHMELZUNG	+	gesellschaftISINNameLand	ISIN or internal ID of investment fund before merger as well as name and country of domicile of company with whose investment funds merger took place
---------------	---	--------------------------	--

or

SONSTIGES	+	blank: <SONSTIGES/>	Information about blank element if reason given is other
-----------	---	---------------------	--

Structure: AENDERUNGSMELDUNG // CHANGE REPORT

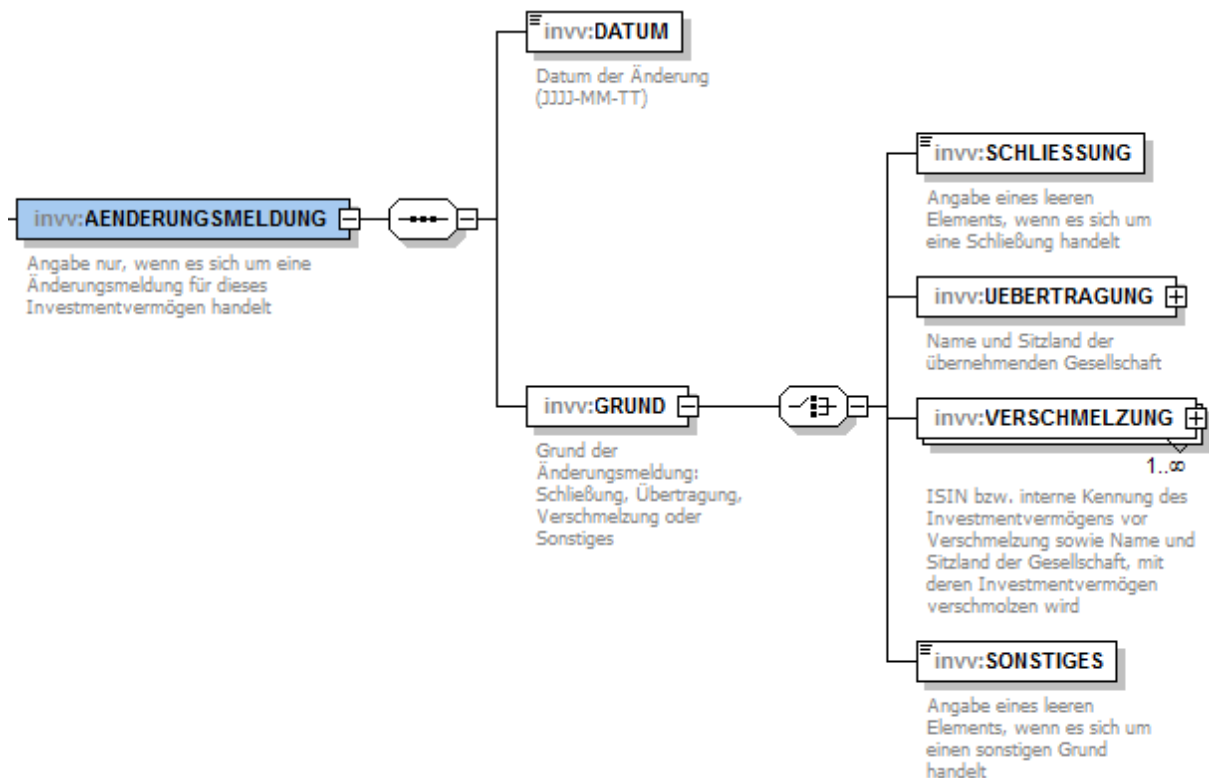

ART INHABER GESCHL (TYPE OF UNIT HOLDER – CLOSED-ENDED)

Figure 4-7

Information on V10390, item 11

GESAMTBETRAG	+	betrag12	Total amount in thousands of euro
ANGABEN	+	see below	Specific information on item 11

ANGABEN (INFORMATION) (can be repeated as often as required)

BETRAG	+	betrag12	Amount in thousands of euro
LAND	+	bbk:isoLand	Country of domicile of unit holder
SEKTOR	+	Code table sektor	Sector of unit holder

Structure: ART_INHABER_GESCHL // TYPE OF UNIT HOLDER - CLOSED-ENDED

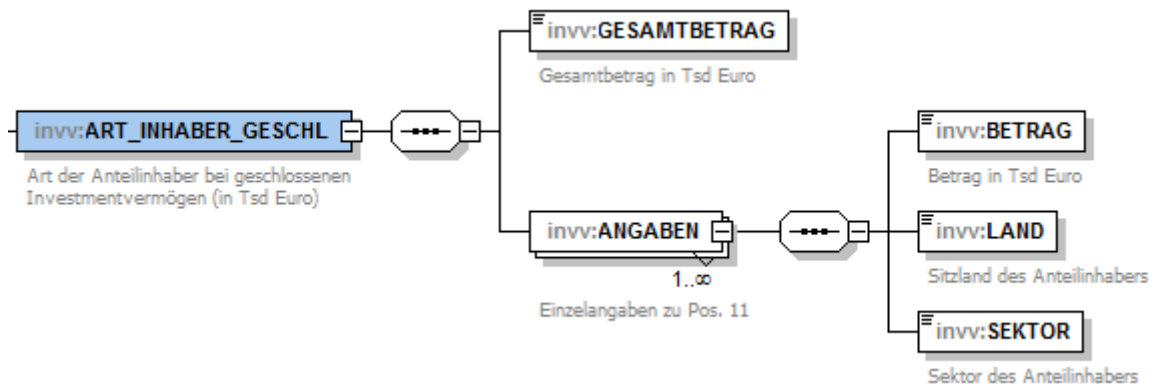

Figure 4-8

ART_LAUFZEIT (TYPE OF MATURITY)

Information on V10390, item 14

UNBEFRISTET	+	blank: <UNBEFRISTET/>	Create blank entry if maturity is not dated
or			
BEFRISTET	+	xs:gYearMonth	Enter date (YYYY-MM) if maturity is dated

ART_RUECKNAHME (TYPE OF REDEMPTION)

Information on V10390, item 15

BOERSENTAEGGL	+	blank: <BOERSENTAEGGL/>	Create entry if unit certificate can be redeemed every trading day
or			
MIND_1_MAL_JAEHRL	+	blank: <MIND_1_MAL_JAEHRL/>	Create entry if unit certificate can be redeemed at least once a year (but not every trading day)
or			
MIND_1_MAL_LFZ	+	blank: <MIND_1_MAL_LFZ/>	Create entry if unit certificate can be redeemed at least once during term (but not only once a year)
<i>fruehestens_nach_x_jahren</i>		0 to 99	Minimum holding period up to earliest possible certificate redemption in years
or			
AUSSCHL_LFZ_ENDE	+	blank: <AUSSCHL_LFZ_ENDE/>	Create entry if unit certificate can only be redeemed at term end or if the investment fund is being wound down
or			
AUSSETZUNG	+	blank: <AUSSETZUNG/>	Create entry if certificate redemption has been suspended
<i>seit</i>		xs:date	Date of suspension (YYYY-MM-DD)
or			
KEINE_AUSSETZUNG	+	blank: <KEINE_AUSSETZUNG/>	Create entry if certificate redemption has not been suspended

Structure: ART_RUECKNAHME // TYPE OF REDEMPTION

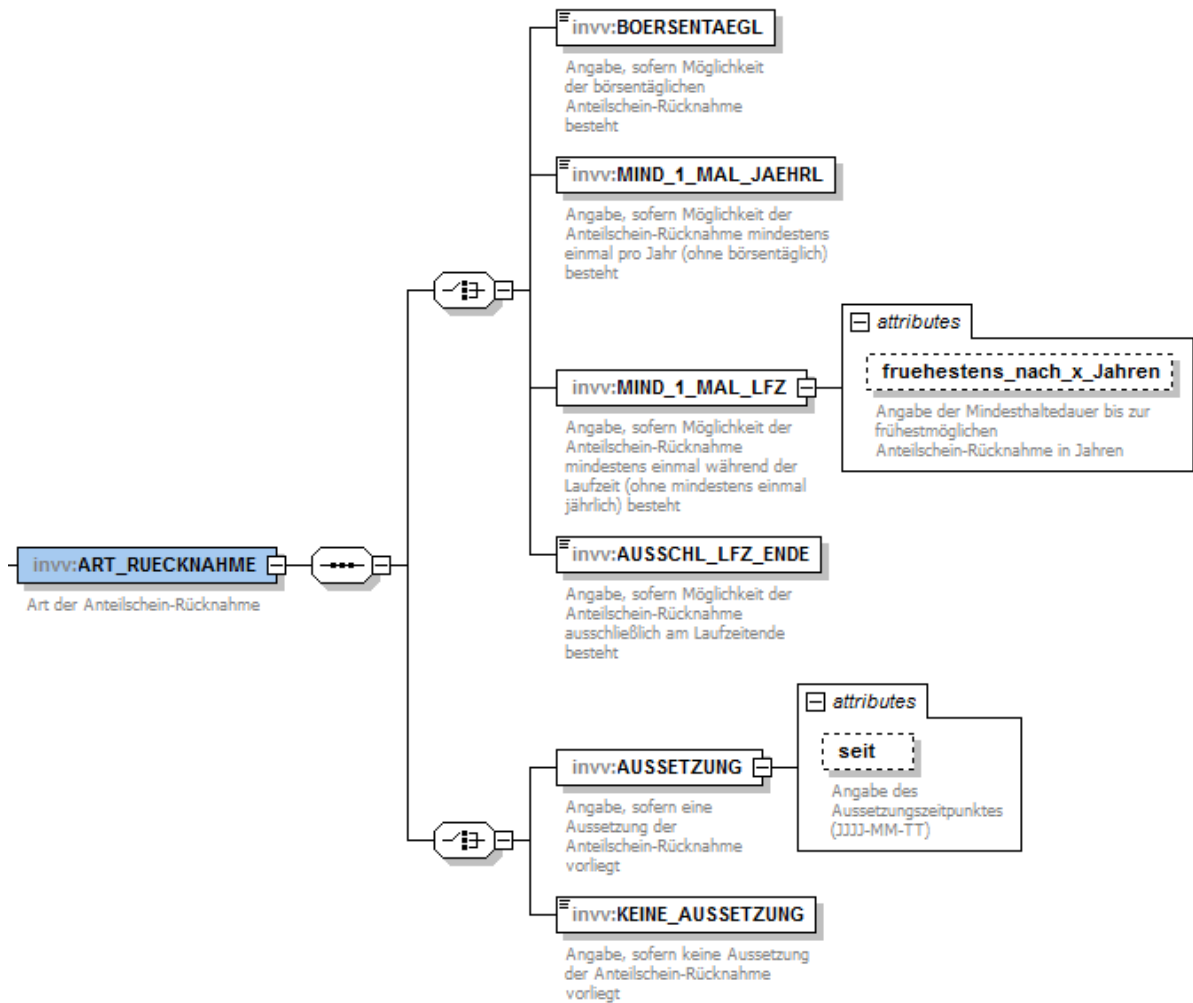

Figure 4-9

INDEX

Information on V10390, item 17

INDEXFONDS_NEIN	+	blank: <INDEXFONDS_NEIN/>	Create entry if investment fund is not an index fund
or			
INDEXFONDS_JA	+	see below	Create entry if investment fund is an index fund

INDEXFONDS JA (INDEX FUND – YES)

BOERSENGEHANDELT	+	bbk: jaNein	Is index fund traded on an exchange?
INDEXABB	+	Code table index_abbildung	Type of index replication
ABGEBILDETER_INDEX	+	see below	Replicated index

ABGEBILDETER INDEX (REPLICATED INDEX)

ISIN	+	bbk: ISIN	ISIN of replicated index
or			
TEXT	+	text40	Replicated index as text if index does not have an ISIN

Structure: INDEX

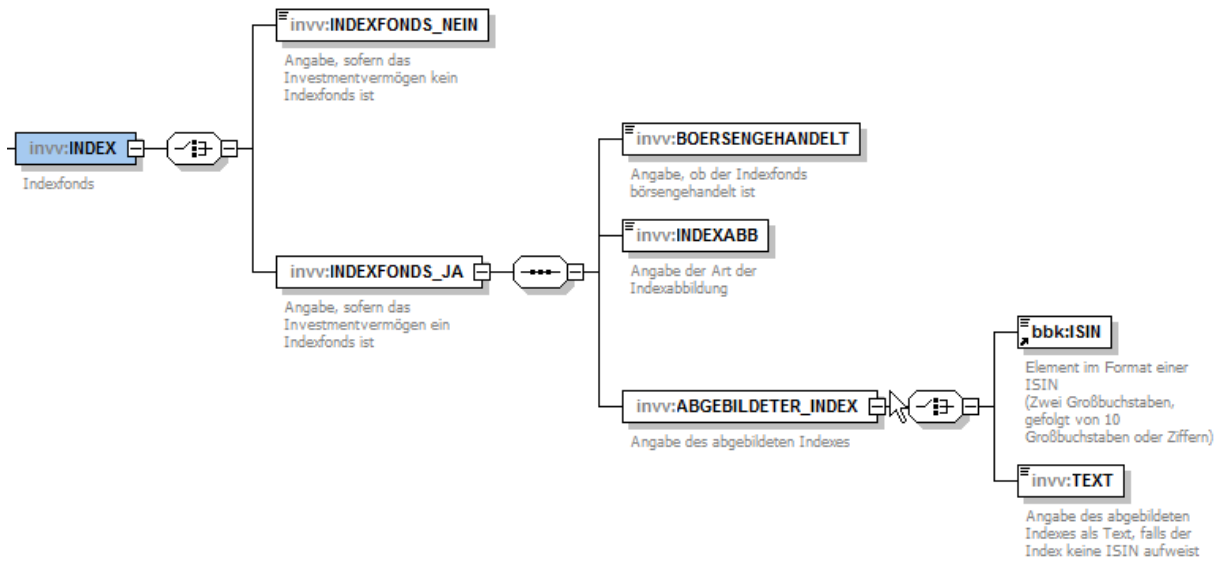

Figure 4-10

UEBERGEORDNET (SUPERORDINATED FUND)

Information on V10390, item 20

ANTEILKLASSE	+	invv_kennung	Superordinated fund if it is a share class
or			
TEILINVV	+	invv_kennung	Superordinated fund if it is a sub-investment fund
or			
OBJEKTGESELLSCHAFT	+	invv_kennung	Superordinated (umbrella) investment fund if it is a real estate company

Example: ALLGEMEIN_INVV (V10390) - investment funds

1 Example

```
<ALLGEMEIN_INVV>
  <BBK_INSTITUTS_ID>00123</BBK_INSTITUTS_ID>
  <INVV_NAME>Beispiel-Investmentvermoegen 1</INVV_NAME>
  <bbk:ISIN>DE00012BSP01</bbk:ISIN>
  <RECHT>DE</RECHT>
  <LEI>123400A1B2C3D4E5F699</LEI>
  <ERSTMELDUNG>
    <DATUM>2012-01-15</DATUM>
    <GRUND>
      <NEUAUFLAGE/>
    </GRUND>
  </ERSTMELDUNG>
  <ORGANISATION>offen - Sondervermoegen</ORGANISATION>
  <TYP>Spezial-AIF - Offener Spezial-AIF - Allgemeiner offener Spezial-AIF</TYP>
  <ART_INHABER_OFFEN>Lebensversicherungen</ART_INHABER_OFFEN>
  <ART_MITTELANLAGE>Aktienfonds</ART_MITTELANLAGE>
  <ART_ERTRAG>Thesaurierungsfonds</ART_ERTRAG>
  <ART_LAUFZEIT>
    <UNBEFRISTET/>
  </ART_LAUFZEIT>
  <ART_RUECKNAHME>
    <BOERSENTAEGEL/>
    <AUSSETZUNG seit="2013-12-31"/>
  </ART_RUECKNAHME>
  <NOTIERUNG>stuecknotiert</NOTIERUNG>
  <INDEX>
    <INDEXFONDS_JA>
      <BOERSENGEHANDELT>nein</BOERSENGEHANDELT>
      <INDEXABB>physisch - vollstaendige Abbildung</INDEXABB>
      <ABGEBILDETER_INDEX>
        <bbk:ISIN>DE000INDEX01</bbk:ISIN>
      </ABGEBILDETER_INDEX>
    </INDEXFONDS_JA>
  </INDEX>
  <WERTGESICHERT>nein</WERTGESICHERT>
  <MASTER>
    <bbk:ISIN>DE00034BSP01</bbk:ISIN>
    <bbk:ISIN>DE00056BSP01</bbk:ISIN>
  </MASTER>
  <UEBERGEORDNET>
    <ANTEILKLASSE>
      <bbk:ISIN>XC00012BSP01</bbk:ISIN>
    </ANTEILKLASSE>
  </UEBERGEORDNET>
</ALLGEMEIN_INVV>
```

2 Example

```

<ALLGEMEIN_INVV>
  <BBK_INSTITUTS_ID>00123</BBK_INSTITUTS_ID>
  <INVV_NAME>Beispiel-Investmentvermoegen 2</INVV_NAME>
  <INTERNE_KNR>DE00012BSP02</INTERNE_KNR>
  <RECHT>US</RECHT>
  <LEI>123400A1B2C3D4E5F699</LEI>
  <ERSTMELDUNG>
    <DATUM>6/15/2012</DATUM>
    <GRUND>
      <NEUAUFLAGE/>
    </GRUND>
  </ERSTMELDUNG>
  <ORGANISATION_GESCHL_SONSTIGE>GmbH & Co. KG</ORGANISATION_GESCHL_SONSTIGE>
  <TYP>Publikumsinvestmentvermoegen - Geschlossener Publikums-AIF</TYP>
  <ART_INHABER_GESCHL>
    <GESAMTBETRAG>9000</GESAMTBETRAG>
    <ANGABEN>
      <BETRAG>5000</BETRAG>
      <LAND>DE</LAND>
      <SEKTOR>Nichtfinanzielle Kapitalgesellschaften (S.11)</SEKTOR>
    </ANGABEN>
    <ANGABEN>
      <BETRAG>3000</BETRAG>
      <LAND>DE</LAND>
      <SEKTOR>Private Haushalte (S.14)</SEKTOR>
    </ANGABEN>
    <ANGABEN>
      <BETRAG>1000</BETRAG>
      <LAND>AT</LAND>
      <SEKTOR>Private Haushalte (S.14)</SEKTOR>
    </ANGABEN>
  </ART_INHABER_GESCHL>
  <ART_MITTELANLAGE>Immobilienfonds</ART_MITTELANLAGE>
  <ART_ERTRAG>Ausschuettungsfonds</ART_ERTRAG>
  <ART_LAUFZEIT>
    <BEFRISTET>2024-06</BEFRISTET>
  </ART_LAUFZEIT>
  <ART_RUECKNAHME>
    <MIND_1_MAL_LFZ fruehestens_nach_x_Jahren="5"/>
  </ART_RUECKNAHME>
  <NOTIERUNG>prozentnotiert</NOTIERUNG>
  <INDEX>
    <INDEXFONDS_NEIN/>
  </INDEX>
  <WERTGESICHERT>nein</WERTGESICHERT>
</ALLGEMEIN_INVV>
  
```

4.4.3 MONATLICH_INVV // MONTHLY INVESTMENT FUND REPORT (V10391)

The monthly report for the individual investment fund is to be filed by the 5th business day of the month following the report month.

The report refers – unless otherwise stated – to the level at the end of the reporting month (last trading day of the month).

For the superordinated fund, the report is to be filed for each share class or each sub-investment fund separately.

Besides the amount of the fund asset, all non-financial and financial asset positions and liabilities – if available – must be broken down separately, including their subdivision by type, maturity, sector and country.

Information about held securities is to be submitted for each security separately (security-for-security reporting system).

Name	Req	Value range / format	Comments
(Formular-Kopf)	+	formular_kopf	BBk institution ID, name and ID of investment fund
WERTPAPIERE	-	see below	Total amount and subdivision of held securities (total amount in thousands of euro and individual security subdivision in euro or number of units)
BANKGUTHABEN	-	bankguthaben (bank deposits)	Total amount and subdivision of bank deposits (in thousands of euro)
DARL_IMMO_GES	-	forderungen (claims)	Total amount and subdivision of loans to property companies (in thousands of euro)
SCHULDSCHEINDARLEHEN	-	forderungen (claims)	Total amount and subdivision of borrower's note loans (in thousands of euro)
UNVERBR_DARL_FORD	-	forderungen (claims)	Total amount and subdivision of unsecured credit claims (in thousands of euro)
FORD_WP_LEIH_GESCH	-	forderungen (claims)	Total amount and subdivision of claims from securities lending and repurchase agreements (in thousands of euro)
SONST_FORDERUNGEN	-	forderungen (claims)	Total amount and subdivision of other claims (in thousands of euro)
DERIVATE_AKTIVA	-	betrag12	Total amount of financial derivatives (assets) (in thousands of euro)
GRUNDSTUECKE_UNBEBAUT	-	nf_vermoegen	Total amount and subdivision of undeveloped land (in thousands of euro)
GRUNDSTUECKE_BEBAUT	-	nf_vermoegen_grundst_beb	Total amount and subdivision of developed land (in thousands of euro)
SCHIFFE	-	nf_vermoegen	Total amount and subdivision of ships, superstructures of ships and ship components and replacement parts (in thousands of euro)
CONTAINER	-	nf_vermoegen	Total amount and subdivision of containers (in thousands of euro)
LUFTFAHRZEUGE	-	nf_vermoegen	Total amount and subdivision of airplanes and airplane components and replacement parts (in thousands of euro)
ENERGIE_ANLAGEN	-	nf_vermoegen	Total amount and subdivision of systems for production, transport and storage of energy (in thousands of euro)

SONSTIGE_NF_VERM	-	nf_vermoegen	Total amount and subdivision of other non-financial assets (in thousands of euro)
BETEILIGUNG_IMMOGESELLSCHAFT	-	beteiligungen (participating interests)	Total amount and subdivision of participating interests in property companies (in thousands of euro)
BETEILIGUNG_OEPP	-	beteiligungen (participating interests)	Total amount and subdivision of participating interests in public-private project companies (in thousands of euro)
BETEILIGUNG_SONST	-	beteiligungen (participating interests)	Total amount and subdivision of participating interests in other companies (in thousands of euro)
SONSTIGES_VERMOEGEN	-	sonst_vermoegen (other assets)	Total amount and subdivision of other assets (in thousands of euro)
LOANS	-	verbindlichkeiten (liabilities)	Total amount and subdivision of borrowing (in thousands of euro)
VERB_WP_LEIH_GESCH	-	verbindlichkeiten (liabilities)	Total amount and subdivision of liabilities from securities lending and repurchase agreements (in thousands of euro)
DERIVATE_PASSIVA	-	betrag12	Total amount of financial derivatives (liabilities) (in thousands of euro)
SONSTIGE_VERBINDLICHKEITEN	-	sonst_verbindlichkeiten	Total amount and subdivision of other liabilities (in thousands of euro)
FONDSVERMOEGEN	+	betrag12	Fund assets (in thousands of euro)
UMLAUF	+	wpNwStueck	Units outstanding as a number of units for investment funds quoted as a number of units and as a nominal value in thousands of euro for investment funds quoted as a percentage
AUSGABE	+	wpKursPreis	Issue price as a price per unit in euro for investment funds quoted as a number of units (at least 2 decimal places) and as a price as a percentage for investment funds quoted as a percentage (at least 3 decimal places)
RUECKNAHME	+	wpKursPreis	Repurchase price as a price per unit in euro for investment funds quoted as a number of units (at least 2 decimal places) and as a price as a percentage for investment funds quoted as a percentage (at least 3 decimal places)
BRUTTOABSATZ	+	wpNwStueck	Gross sales as a number of units for investment funds quoted as a number of units and as a nominal value in thousands of euro for investment funds quoted as a percentage
MITTELZUFLUESSE	+	betrag12	Inflows from sale of fund units (in thousands of euro)
MITTELABFLUESSE	+	mittelabfluesse (outflows)	Outflows from repurchase of fund units (in thousands of euro)
ERTRAGSAUSSCHUETTUNG	+	betrag12	Total amount of earnings distributions (in thousands of euro)

```

    </WERTPAPIER_OHNE_ISIN>
  </WERTPAPIERE>
  <BANKGUTHABEN>
    <GESAMTBETRAG>3000</GESAMTBETRAG>
    <ANGABEN>
      <BETRAG>3000</BETRAG>
      <WAEHRUNG>EUR</WAEHRUNG>
      <LAND>DE</LAND>
      <SEKTOR>Kreditinstitute (S.122)</SEKTOR>
      <FRISTIGKEIT>taeglich</FRISTIGKEIT>
    </ANGABEN>
  </BANKGUTHABEN>
  <FORD_WP_LEIH_GESCH>
    <GESAMTBETRAG>50</GESAMTBETRAG>
    <ANGABEN>
      <BETRAG>50</BETRAG>
      <WAEHRUNG>EUR</WAEHRUNG>
      <LAND>DE</LAND>
      <SEKTOR>Kreditinstitute (S.122)</SEKTOR>
      <FRISTIGKEIT>bis 1 Monat</FRISTIGKEIT>
      <VERBUNDENES_UNTERNEHMEN>nein</VERBUNDENES_UNTERNEHMEN>
    </ANGABEN>
  </FORD_WP_LEIH_GESCH>
  <DERIVATE_AKTIVA>30</DERIVATE_AKTIVA>
  <SONSTIGES_VERMOEGEN>
    <GESAMTBETRAG>500</GESAMTBETRAG>
    <ZINSEN_EINLAGEN>300</ZINSEN_EINLAGEN>
    <ZINSEN_WERTPAPIERE>100</ZINSEN_WERTPAPIERE>
    <FORDERUNGEN>50</FORDERUNGEN>
  </SONSTIGES_VERMOEGEN>
  <DERIVATE_PASSIVA>10</DERIVATE_PASSIVA>
  <SONSTIGE_VERBINDLICHKEITEN>
    <GESAMTBETRAG>100</GESAMTBETRAG>
    <ZINSEN_AUFGELAUFEN>20</ZINSEN_AUFGELAUFEN>
  </SONSTIGE_VERBINDLICHKEITEN>
  <FONDSVERMOEGEN>4441</FONDSVERMOEGEN>
  <UMLAUF>
    <STUECKZAHL>100000</STUECKZAHL>
  </UMLAUF>
  <AUSGABE>
    <PREIS>46,63</PREIS>
  </AUSGABE>
  <RUECKNAHME>
    <PREIS>44,41</PREIS>
  </RUECKNAHME>
  <BRUTTOABSATZ>
    <STUECKZAHL>50</STUECKZAHL>
  </BRUTTOABSATZ>
    <MITTELZUFLUESSE>2</MITTELZUFLUESSE>
  <MITTELABFLUESSE>
    <GESAMTBETRAG>5</GESAMTBETRAG>
    <SUBSTANZ_KAPITAL>1</SUBSTANZ_KAPITAL>
  </MITTELABFLUESSE>
  <ERTRAGSAUSSCHUETTUNG>
    <GESAMTBETRAG>40</GESAMTBETRAG>
  </ERTRAGSAUSSCHUETTUNG>
</MONATLICH_INVV>

```

2 Focus on real estate

```
<MONATLICH_INVV>
  <BBK_INSTITUTS_ID>00123</BBK_INSTITUTS_ID>
  <INVV_NAME>Beispiel Immobilienfonds</INVV_NAME>
  <INTERNE_KNR>DE00012BSP02</INTERNE_KNR>
  <BANKGUTHABEN>
    <GESAMTBETRAG>8000</GESAMTBETRAG>
    <ANGABEN>
      <BETRAG>3000</BETRAG>
      <WAEHRUNG>EUR</WAEHRUNG>
      <LAND>DE</LAND>
      <SEKTOR>Kreditinstitute (S.122)</SEKTOR>
      <FRISTIGKEIT>taeglich</FRISTIGKEIT>
    </ANGABEN>
    <ANGABEN>
      <BETRAG>2000</BETRAG>
      <WAEHRUNG>EUR</WAEHRUNG>
      <LAND>DE</LAND>
      <SEKTOR>Kreditinstitute (S.122)</SEKTOR>
      <FRISTIGKEIT>ueber 6 Monate bis 1 Jahr</FRISTIGKEIT>
    </ANGABEN>
    <ANGABEN>
      <BETRAG>2000</BETRAG>
      <WAEHRUNG>GBP</WAEHRUNG>
      <LAND>GB</LAND>
      <SEKTOR>Kreditinstitute (S.122)</SEKTOR>
      <FRISTIGKEIT>ueber 3 Monate bis 6 Monate</FRISTIGKEIT>
    </ANGABEN>
    <ANGABEN>
      <BETRAG>1000</BETRAG>
      <WAEHRUNG>USD</WAEHRUNG>
      <LAND>DE</LAND>
      <SEKTOR>Kreditinstitute (S.122)</SEKTOR>
      <FRISTIGKEIT>bis 1 Monat</FRISTIGKEIT>
    </ANGABEN>
  </BANKGUTHABEN>
  <DARL_IMMO_GES>
    <GESAMTBETRAG>100</GESAMTBETRAG>
    <ANGABEN>
      <BETRAG>100</BETRAG>
      <WAEHRUNG>EUR</WAEHRUNG>
      <LAND>DE</LAND>
      <SEKTOR>Nichtfinanzielle Kapitalgesellschaften (S.11)</SEKTOR>
      <FRISTIGKEIT>ueber 5 Jahre bis 10 Jahre</FRISTIGKEIT>
      <VERBUNDENES_UNTERNEHMEN>ja</VERBUNDENES_UNTERNEHMEN>
    </ANGABEN>
  </DARL_IMMO_GES>
  <GRUNDSTUECKE_UNBEBAUT>
    <GESAMTBETRAG>1000</GESAMTBETRAG>
    <ANGABEN>
      <BETRAG>1000</BETRAG>
      <LAND>FR</LAND>
      <ANZAHL>1</ANZAHL>
    </ANGABEN>
  </GRUNDSTUECKE_UNBEBAUT>
  <GRUNDSTUECKE_BEBAUT>
    <GESAMTBETRAG>5000</GESAMTBETRAG>
    <ANGABEN>
      <BETRAG>3000</BETRAG>
      <LAND>DE</LAND>
      <ANZAHL>4</ANZAHL>
      <NUTZUNGSART>Buero</NUTZUNGSART>
    </ANGABEN>
```

```

<ANGABEN>
  <BETRAG>1500</BETRAG>
  <LAND>DE</LAND>
  <ANZAHL>2</ANZAHL>
  <NUTZUNGSART>Wohnen</NUTZUNGSART>
</ANGABEN>
<ANGABEN>
  <BETRAG>500</BETRAG>
  <LAND>IT</LAND>
  <ANZAHL>1</ANZAHL>
  <NUTZUNGSART>Buero</NUTZUNGSART>
</ANGABEN>
</GRUNDSTUECKE_BEBAUT>
<BETEILIGUNG_IMMOGESELLSCHAFT>
  <GESAMTBETRAG>2000</GESAMTBETRAG>
  <ANGABEN>
    <BETRAG>2000</BETRAG>
    <LAND>US</LAND>
  </ANGABEN>
</BETEILIGUNG_IMMOGESELLSCHAFT>
<SONSTIGES_VERMOEGEN>
  <GESAMTBETRAG>200</GESAMTBETRAG>
  <FORDERUNGEN>100</FORDERUNGEN>
</SONSTIGES_VERMOEGEN>
<KREDITE>
  <GESAMTBETRAG>500</GESAMTBETRAG>
  <ANGABEN>
    <BETRAG>300</BETRAG>
    <WAEHRUNG>EUR</WAEHRUNG>
    <LAND>NL</LAND>
    <SEKTOR>Kreditinstitute (S.122)</SEKTOR>
    <FRISTIGKEIT>ueber 5 Jahre bis 10 Jahre</FRISTIGKEIT>
    <MINDESTRESERVEPFL_INST>ja</MINDESTRESERVEPFL_INST>
  </ANGABEN>
  <ANGABEN>
    <BETRAG>200</BETRAG>
    <WAEHRUNG>EUR</WAEHRUNG>
    <LAND>DE</LAND>
    <SEKTOR>Kreditinstitute (S.122)</SEKTOR>
    <FRISTIGKEIT>ueber 3 Jahre bis 4 Jahre</FRISTIGKEIT>
    <MINDESTRESERVEPFL_INST>nein</MINDESTRESERVEPFL_INST>
  </ANGABEN>
</KREDITE>
<SONSTIGE_VERBINDLICHKEITEN>
  <GESAMTBETRAG>20</GESAMTBETRAG>
</SONSTIGE_VERBINDLICHKEITEN>
<FONDSVERMOEGEN>15780</FONDSVERMOEGEN>
<UMLAUF>
  <STUECKZAHL>1000000</STUECKZAHL>
</UMLAUF>
<AUSGABE>
  <PREIS>15,78</PREIS>
</AUSGABE>
<RUECKNAHME>
  <PREIS>15,78</PREIS>
</RUECKNAHME>
<BRUTTOABSATZ>
  <STUECKZAHL>400</STUECKZAHL>
</BRUTTOABSATZ>
<MITTELZUFUESSE>6</MITTELZUFUESSE>
<MITTELABFLUESSE>
  <GESAMTBETRAG>0</GESAMTBETRAG>
</MITTELABFLUESSE>
<ERTRAGSAUSSCHUETTUNG>
    
```

```
<GESAMTBETRAG>500</GESAMTBETRAG>  
</ERTRAGSAUSSCHUETTUNG>  
</MONATLICH_INVV>
```

3 Focus on ships

```
<MONATLICH_INVV>  
<BBK_INSTITUTS_ID>00123</BBK_INSTITUTS_ID>  
<INVV_NAME>Beispiel Schiffsfonds</INVV_NAME>  
<bbk:ISIN>DE00012BSP03</bbk:ISIN>  
<BANKGUTHABEN>  
<GESAMTBETRAG>8000</GESAMTBETRAG>  
<ANGABEN>  
<BETRAG>5000</BETRAG>  
<WAEHRUNG>EUR</WAEHRUNG>  
<LAND>DE</LAND>  
<SEKTOR>Kreditinstitute (S.122)</SEKTOR>  
<FRISTIGKEIT>taeglich</FRISTIGKEIT>  
</ANGABEN>  
<ANGABEN>  
<BETRAG>3000</BETRAG>  
<WAEHRUNG>EUR</WAEHRUNG>  
<LAND>DE</LAND>  
<SEKTOR>Kreditinstitute (S.122)</SEKTOR>  
<FRISTIGKEIT>ueber 6 Monate bis 1 Jahr</FRISTIGKEIT>  
</ANGABEN>  
</BANKGUTHABEN>  
<SCHIFFE>  
<GESAMTBETRAG>30000</GESAMTBETRAG>  
<ANGABEN>  
<BETRAG>12000</BETRAG>  
<LAND>DE</LAND>  
<ANZAHL>1</ANZAHL>  
</ANGABEN>  
<ANGABEN>  
<BETRAG>10000</BETRAG>  
<LAND>PL</LAND>  
<ANZAHL>1</ANZAHL>  
</ANGABEN>  
<ANGABEN>  
<BETRAG>8000</BETRAG>  
<LAND>CN</LAND>  
<ANZAHL>1</ANZAHL>  
</ANGABEN>  
</SCHIFFE>  
<SONSTIGE_NF_VERM>  
<GESAMTBETRAG>500</GESAMTBETRAG>  
<ANGABEN>  
<BETRAG>300</BETRAG>  
<LAND>DK</LAND>  
<ANZAHL>2</ANZAHL>  
</ANGABEN>  
<ANGABEN>  
<BETRAG>200</BETRAG>  
<LAND>IE</LAND>  
<ANZAHL>1</ANZAHL>  
</ANGABEN>  
</SONSTIGE_NF_VERM>  
<KREDITE>  
<GESAMTBETRAG>12000</GESAMTBETRAG>  
<ANGABEN>  
<BETRAG>8000</BETRAG>  
<WAEHRUNG>EUR</WAEHRUNG>  
<LAND>NL</LAND>
```

```

        <SEKTOR>Kreditinstitute (S.122)</SEKTOR>
        <FRISTIGKEIT>ueber 5 Jahre bis 10 Jahre</FRISTIGKEIT>
        <MINDESTRESERVEPFL_INST>ja</MINDESTRESERVEPFL_INST>
    </ANGABEN>
    <ANGABEN>
        <BETRAG>3000</BETRAG>
        <WAEHRUNG>EUR</WAEHRUNG>
        <LAND>DE</LAND>
        <SEKTOR>Kreditinstitute (S.122)</SEKTOR>
        <FRISTIGKEIT>ueber 5 Jahre bis 10 Jahre</FRISTIGKEIT>
        <MINDESTRESERVEPFL_INST>nein</MINDESTRESERVEPFL_INST>
    </ANGABEN>
    <ANGABEN>
        <BETRAG>1000</BETRAG>
        <WAEHRUNG>EUR</WAEHRUNG>
        <LAND>DE</LAND>
        <SEKTOR>Kreditinstitute (S.122)</SEKTOR>
        <FRISTIGKEIT>ueber 3 Jahre bis 4 Jahre</FRISTIGKEIT>
        <MINDESTRESERVEPFL_INST>nein</MINDESTRESERVEPFL_INST>
    </ANGABEN>
</KREDITE>
<FONDSVERMOEGEN>26500</FONDSVERMOEGEN>
<UMLAUF>
    <NOMINALWERT>33125</NOMINALWERT>
</UMLAUF>
<AUSGABE>
    <KURS>80,000</KURS>
</AUSGABE>
<RUECKNAHME>
    <KURS>80,000</KURS>
</RUECKNAHME>
<BRUTTOABSATZ>
    <NOMINALWERT>100</NOMINALWERT>
</BRUTTOABSATZ>
<MITTELZUFLUESSE>80</MITTELZUFLUESSE>
<MITTELABFLUESSE>
    <GESAMTBETRAG>1500</GESAMTBETRAG>
    <SUBSTANZ_KAPITAL>1500</SUBSTANZ_KAPITAL>
</MITTELABFLUESSE>
<ERTRAGSAUSSCHUETTUNG>
    <GESAMTBETRAG>750</GESAMTBETRAG>
</ERTRAGSAUSSCHUETTUNG>
</MONATLICH_INVV>
    
```

4.4.4 BEREINIGUNGEN // ADJUSTMENTS (V10392)

The monthly report for individual investment funds is to be filed by the 5th business day of the month following the reporting month.

Information on adjustments is to be reported for financial derivatives, non-financial assets and participating interests. For these items – with the exception of financial derivatives – it is necessary to break each of them down by country. When calculating the adjustments, only those changes in value between the reporting month and the previous month due to price and/or exchange rate fluctuations are considered. If there are losses in value, a negative amount must be reported.

For financial derivatives, purchases and sales made during the reporting period are not to be included in the calculation of the adjustments. On the other hand, for non-financial assets and participating interests, changes in value as well as the profits and losses from sales are to be included in the calculation.

A report is also to be submitted when no adjustments are required in the reporting month. In this case, a blank or zero report is to be submitted.

For the superordinated fund, the report is to be filed for each share class or each sub-investment asset separately.

Name	Req	Value range / format	Comments
(Formular-Kopf)	+	formular_kopf	BBk institution ID, name and ID of investment fund
DERIVATE_AKTIVA	-	betrag12	Total amount of adjustments for financial derivatives (assets) (in thousands of euro)
GRUNDSTUECKE_UNBEBAUT	-	angaben_ber	Total amount of adjustments and subdivision of undeveloped land (in thousands of euro)
GRUNDSTUECKE_BEBAUT	-	angaben_ber	Total amount of adjustments and subdivision of developed land (in thousands of euro)
SCHIFFE	-	angaben_ber	Total amount of adjustments and subdivision of ships, superstructures of ships and ship components and replacement parts (in thousands of euro)
CONTAINER	-	angaben_ber	Total amount of adjustments and subdivision of containers (in thousands of euro)
LUFTFAHRZEUGE	-	angaben_ber	Total amount of adjustments and subdivision of airplanes and airplane components and replacement parts (in thousands of euro)
ENERGIE_ANLAGEN	-	angaben_ber	Total amount of adjustments and subdivision of systems of production, transport and storage of energy (in thousands of euro)
SONSTIGE_NF_VERM	-	angaben_ber	Total amount of adjustments and subdivision of other non-financial assets (in thousands of euro)
BETEILIGUNG_IMMOGESELLSCHAFT	-	angaben_ber	Total amount of adjustments and subdivision of participating interests in property companies (in thousands of euro)
BETEILIGUNG_OEPP	-	angaben_ber	Total amount of adjustments and subdivision of participating interests in public-private project companies (in thousands of euro)

BETEILIGUNG_SONST	-	angaben_ber	Total amount of adjustments and sub-division of participating interests in other companies (in thousands of euro)
DERIVATE_PASSIVA	-	betrag12	Total amount of adjustments for financial derivatives (liabilities) (in thousands of euro)

Example: BEREINIGUNGEN // ADJUSTMENTS (V10392)

1 Changes in value

```

<BEREINIGUNGEN>
  <BBK_INSTITUTS_ID>00123</BBK_INSTITUTS_ID>
  <INVV_NAME>Beispiel Wertaenderungen</INVV_NAME>
  <bbk:ISIN>DE00012BSP01</bbk:ISIN>
  <DERIVATE_AKTIVA>-100</DERIVATE_AKTIVA>
  <GRUNDSTUECKE_UNBEBAUT>
    <GESAMTBETRAG>1500</GESAMTBETRAG>
    <ANGABEN>
      <BETRAG>2000</BETRAG>
      <LAND>DE</LAND>
    </ANGABEN>
    <ANGABEN>
      <BETRAG>-500</BETRAG>
      <LAND>AT</LAND>
    </ANGABEN>
  </GRUNDSTUECKE_UNBEBAUT>
  <GRUNDSTUECKE_BEBAUT>
    <GESAMTBETRAG>-1000</GESAMTBETRAG>
    <ANGABEN>
      <BETRAG>-600</BETRAG>
      <LAND>DE</LAND>
    </ANGABEN>
    <ANGABEN>
      <BETRAG>-400</BETRAG>
      <LAND>GB</LAND>
    </ANGABEN>
  </GRUNDSTUECKE_BEBAUT>
  <BETEILIGUNG_IMMOGESELLSCHAFT>
    <GESAMTBETRAG>700</GESAMTBETRAG>
    <ANGABEN>
      <BETRAG>700</BETRAG>
      <LAND>US</LAND>
    </ANGABEN>
  </BETEILIGUNG_IMMOGESELLSCHAFT>
  <DERIVATE_PASSIVA>20</DERIVATE_PASSIVA>
</BEREINIGUNGEN>

```

2 Zero report (focus on ship funds)

```
<BEREINIGUNGEN>
  <BBK_INSTITUTS_ID>00123</BBK_INSTITUTS_ID>
  <INVV_NAME>Beispiel Null-Meldung</INVV_NAME>
  <bbk:ISIN>DE00012BSP02</bbk:ISIN>
  <DERIVATE_AKTIVA>0</DERIVATE_AKTIVA>
  <SCHIFFE>
    <GESAMTBETRAG>0</GESAMTBETRAG>
    <ANGABEN>
      <BETRAG>0</BETRAG>
      <LAND>DE</LAND>
    </ANGABEN>
  </SCHIFFE>
</BEREINIGUNGEN>
```

3 Blank report

```
<BEREINIGUNGEN>
  <BBK_INSTITUTS_ID>00123</BBK_INSTITUTS_ID>
  <INVV_NAME>Beispiel Leere Meldung</INVV_NAME>
  <bbk:ISIN>DE00012BSP03</bbk:ISIN>
</BEREINIGUNGEN>
```

5 Appendix

5.1 Code table organisationsform

XML element: ORGANISATION

Code list: Form of organisation of investment fund

XML schema
Open - specialised fund
Open - investment stock corporation with changeable capital
Open - investment limited partnership
Closed - investment stock corporation with fixed capital
Closed - investment limited partnership

5.2 Code table typ

XML element: TYP

Code list: Type of investment fund

XML schema
Investment fund open to the general public - Undertakings for Collective Investment in Transferable Securities (UCITS)
Investment fund open to the general public - open-ended public AIF - mixed investment fund
Investment fund open to the general public - open-ended public AIF - other investment fund
Investment fund open to the general public - open-ended public AIF - fund of hedge fund
Investment fund open to the general public - open-ended public AIF - specialised real estate fund
Investment fund open to the general public - closed-ended public AIF
Specialised AIF - open-ended specialised AIF - general open-ended specialised AIF
Specialised AIF - open-ended specialised AIF - hedge fund
Specialised AIF - open-ended specialised AIF - specialised AIF with fixed investment conditions
Specialised AIF - closed-ended specialised AIF

5.3 Code table art_inhaber_offen

XML element: ART_INHABER_OFFEN

Code list: Type of unit holder – open-ended investment fund

XML schema
Deposit-taking corporations
Life insurance corporations
Other insurance corporations
Pension funds
Other financial intermediaries
Financial auxiliaries
Non-financial corporations

Central government
State government
Local government
Social security funds
Public and church supplementary pension funds
Non-profit institutions serving households and other
Non-residents

5.4 Code table art_mittel

XML element: ART_MITTELANLAGE
Code list: Type of fund according to investment activity

XML schema
Equity-based fund
Bond-based fund
Mixed securities-based fund
Real estate fund
Money market fund (excl money market fund with short maturity structure)
Money market fund with short maturity structure
Hedge fund
Derivatives fund
Pension mutual fund
Infrastructure fund
Commodities fund
Credit fund
Ship fund
Airplane fund
Energy fund
Private equity fund (excl venture capital fund)
Venture capital fund
Leasing fund
Other fund

5.5 Code table art_ertrag

XML element: ART_ERTRAG
Code list: Type of fund according to income use

XML schema
Distribution fund
Growth fund

5.6 Code table notierung

XML element: NOTIERUNG
Code list: Quotation type for fund units

XML schema

Quoted as a number of units

Quoted as a percentage

5.7 Code table index_abbildung

XML element: INDEXABB

Code list: Type of index replication

XML schema
Physical - full replication
Physical - partial replication
Synthetic

5.8 Code table nutzungsart

XML element: NUTZUNGSART

Code list: Type of use of developed land

XML schema
Office
Retail/Restaurant
Industry
Hotel
Residential
Other

5.9 Code table wpArt

XML element: WERTPAPIERART

Code list: Type of security according to ESA 2010

XML schema
Short-term debt securities (F.31)
Long-term debt securities (F.32)
Listed shares (F.511)
Unlisted shares (F.512)
Other equity (F.519)
Money market fund (MMF) shares/units (F.521)
Non-MMF investment fund shares/units (F.522)

5.10 Code table fristigkeit

XML element: FRISTIGKEIT

Code list: Maturity

XML schema
Daily
Up to 1 month
More than 1 month and up to 3 months

More than 3 months and up to 6 months
More than 6 months and up to 1 year
More than 1 year and up to 2 years
More than 2 years and up to 3 years
More than 3 years and up to 4 years
More than 4 years and up to 5 years
More than 5 years and up to 10 years
More than 10 years

5.11 Code table sektor

XML element: SEKTOR

Code list: Issuer sector according to ESA 2010

XML schema
Non-financial corporations (S.11)
Central bank (S.121)
Deposit-taking corporations except the central bank (S.122)
Money market funds (S.123)
Non-MMF investment funds (S.124)
Other financial intermediaries (S.125)
Financial auxiliaries (S.126)
Captive financial institutions and money lenders (S.127)
Insurance corporations (S.128)
Pension funds (S.129)
Central government (S.1311)
State government (S.1312)
Local government (S.1313)
Social security funds (S.1314)
Households (S.14)
Non-profit institutions serving households (S.15)